

Mining & Mineral Processing

Mining and slurry valve solutions from ITT



ITT

ENGINEERED FOR LIFE

ITT's Mining / Slurry Capabilities

ITT is a global leader in fluid handling with 65 years of design, manufacture and fabrication of engineered valves with specific expertise in slurry applications.

Mining customers around the world depend on ITT Engineered Valves for slurry process expertise, cost effective valve solutions, reliable delivery, and after-sale support.

We approach each customer's requirements with the certainty that we have the right product to fit the most challenging valve application.

Our valves provide:

- Better valve performance in mining and processing of metals and minerals
- Less unscheduled maintenance downtime
- Improved plant performance and pipeline reliability
- Safety for operators



ITT OFFERS YOU CHOICES

ITT supplies a wide range of engineered valve products that are designed to solve the most challenging applications in the mining industry. Mines and mineral processing plants around the world use our process-proven Fabri® knifegate and slurry valves, Dia-Flo® diaphragm valves, and Cam-Line® and Cam-Tite® ball valves to handle abrasive, erosive, and corrosive slurry and chemical applications.

ITT OFFERS YOU PEACE OF MIND

The number one concern in mining is safety. The industry demands solutions that will improve the mining environment as well as the bottom line. ITT works with its customers as a consultant to insure the best solution to their valve applications, with a constant eye on keeping with our core values of safety.

ITT OFFERS YOU SOLUTIONS

Abrasive and often corrosive mining slurries quickly attack unprotected or misapplied valves, pumps and other equipment in mining process lines. This creates the need for frequent repairs that lead to unsafe conditions and system downtime. In order to safely minimize abrasion, corrosion and system downtime, ITT valves are designed and engineered with specific mining applications in mind.

We offer a comprehensive product portfolio. The C/F 133 series valve is one of the safest and most durable slurry valves on the market. The 33 PTA, 33 PTD and C/F 33 valves are designed for light to heavy slurry service. The patented, perimeter seated, bi-directional C67 series valve is engineered for mining applications that require tight sealing capabilities. The OM150 is well suited for applications that require corrosion and abrasion resistance.

To meet the requirements of each application, ITT has the ability to manufacture standard and customized, lined and unlined valves in a wide variety of materials.



Milling

There are many types of process machinery to reduce the size of the ore and allow it to pass through to the next stages. These are found in both the primary and secondary milling stages. Some are high pressure grinding mills, autogenous and semiautogenous (SAG) mills, cone crushers and ball mills.

This is where valves see the most physical demands in mining operations. To handle these types of operations, ITT relies on the rugged **33 PTD** to provide extended valve life for its customers. The **33 PTA** with its wide seats is well suited for slurries with high percent of solids and large particle sizes.



Challenges

A typical challenge encountered in the mining process is particle settling. This is due to a slow slurry velocity combined with a large particle size (12–18mm). The valve may not be able to close because of solids settling at the bottom of the valve. This issue is further complicated because most mining operations find that their pumps need to be changed every 1800 hours on average. If you can't close the valve you can't isolate the pump.

If this is the case ITT recommends using the **C/F 33/133** style valve. The **C/F 33/133** valves are ported slide gate valves specially designed for the gate to move a disc of slurry material out of the flow path and allow the gate to completely close the valve.



33 PTA



33 PTD



C/F 33/133

Cyclone

Cyclones are used to separate mineral ore based on size. Through the process, the ore is separated into large and small diameters. Larger sizes are separated from the smaller where they will continue in the cyclone process until becoming a usable size. ITT offers multiple valves to suit each mine's need including: **33 PTA**, **C/F 33**, **C/F 133** and the **33 PTD** in a secondary cyclone application. **OM150** valves can also be used.



OM150



C/F 33/133



33 PTA



33 PTD

Flotation Cell or Column Thickeners

The purpose of a flotation cell or column thickeners is to begin separating particles in the slurry. The process can be used to separate any two different particles and operates by the surface chemistry of the particles. In flotation, bubbles are introduced to bind particles and bring the two to the surface.

The addition of flotation reagents also effects the operation of these processes. These commonly include collectors, frothers, extenders, activators, depressants, deactivators, flocculents, and dispersants.

You will commonly find ITT's 33 PTD valve installed in this process. Also our **C/F 33**, **C/F 133** or **OM150** can be used.

Clarifiers and Thickeners

Clarifiers and thickeners rely on gravity to separate suspended solids. Rubber lined straightway diaphragm valves can be used on clarifier inlet, overflow outlet, flocculent, sludge piping depending on solid content, and other chemical feed piping or underflow.

Froth Flotation Cells

Diaphragm valves can be used on pneumatic or mechanical flotation cells on feed lines, wash water and / or collector reagent addition lines.

Typical Configuration: rubber lined straightway valve for feed and wash water and plastic lined weir valve for chemical addition.



C/F 33/133

33 PTD

Dia-Flo®
Diaphragm Valve

OM150

Mining & Mineral Processing

Filter Press

Vacuum or press filters are an essential step in the mining process to separate water from the minerals. This is mostly done mechanically, although thermal drying can be used.

The transportation of the minerals at this stage is done through our **33 PTD** valves due to the smaller particle size, although our **C/F 33**, **C/F 133**, **33 PTA** or **OM150** valve can be used depending on the particular media characteristics.



Roaster / Autoclave

Roasting is a metallurgical process involving gas-solids reactions at elevated temperatures with the goal of purifying the metal component(s). Often before roasting, the ore has already been partially purified e.g., by froth flotation. The concentrate is mixed with other materials to facilitate the process. The **C67** is recommended, while the **OM150** and **33 PTD** are other options.



Mining & Mineral Processing

Leaching

The minerals in precious metal mining may need to be concentrated by a process called leaching. Gold, in particular is done by adding cyanide to the ore slurry and leaching the gold into a solution.

To handle the harsh chemicals, you can rely on our Dia-Flo® or Cam-Tite® valves.



Tailings

Tailings are the materials left over after separating the valuable minerals from the unusable portion of an ore. Tailings are distinct from overburden or waste rock, which are the materials overlying an ore or mineral body that are displaced during mining without being processed.

Mine tailings are usually produced from the mill in slurry form (a mixture of fine mineral particles and water). Customers will have the best results by using the **33 PTD** valve.

Rubber lined straightway diaphragm valves are excellent for tailings with low pressure drop and ability to seal over entrained solids. Tailings applications may be limited due to size and pressure limitations.



Cam-Tite® Ball Valve



33 PTD



Dia-Flo®
Diaphragm Valve

Process Water

Water is a constant in every type of mining, because of this ITT has numerous valves available for water based applications. Some applications use water to transport solids in a fine solution or slurry to various processes in a plant. Other applications consume water as part of the process.

Our Dia-Flo® valves can handle those water applications as well as our **33PTD** and **33PTA** valves.

Drains and Sampling

Rubber lined weir diaphragm valves are excellent for drains and sampling due to the multiturn characteristics and ability to seal over entrained solids.

Demineralizers

Steam is used in conjunction with a boiler for many mining applications. Demineralizers eliminate efficiency robbing scale in the boiler tubes by removing the minerals in the water for the boiler. ITT recommends using plastic lined weir valves.



Dia-Flo®
Diaphragm Valve



33 PTA



33 PTD

Mining & Mineral Processing

Chemical Feed

Many mines are heavy users of various types of aggressive chemicals. Rubber or plastic lined weir diaphragm valves are the valve of choice for chemical feed injection due to their throttling, ability to seal over solids, streamlined flow path and tolerance to crystallization.



Dia-Flo® Diaphragm Valve

Electrowinning

Removing gold from a solution can be done by a process known as electrowinning. When two electrodes (cathode and anode) are placed in a solution containing metal ions while an electric current is passed between them, the metal can be deposited on the negative electrode. The solutions used in the electrowinning process are highly corrosive and dangerous. For this reason, the use of a discharging valve is not recommended. ITT's Dia-Flo diaphragm valves are an excellent choice for the electrowinning process because they are non-discharging, can be lined with compatible plastic materials and are a cost effective solution for the relatively small line sizes present in this application.



Mining Valve Selection Guide

Type of Mining	Gold	Silver	Copper	Lead & Zinc	Cobalt & Nickel	Phosphate	Iron Ore	
Operation								
Primary Milling	33 PTA 33 PTD C/F 33/133	33 PTA 33 PTD C/F 33/133	33 PTA 33 PTD C/F 33/133	33 PTA 33 PTD C/F 33/133	33 PTA 33 PTD C/F 33/133	33 PTA 33 PTD C/F 33/133	33 PTA 33 PTD C/F 33/133	
Primary Cyclone	33 PTA 33 PTD C/F 33/133	33 PTA 33 PTD C/F 33/133	33 PTA 33 PTD C/F 33/133	33 PTA 33 PTD C/F 33/133	33 PTA 33 PTD C/F 33/133	33 PTA 33 PTD C/F 33/133	33 PTA 33 PTD C/F 33/133	
Secondary Milling	33 PTA 33 PTD C/F 33/133	33 PTA 33 PTD C/F 33/133	33 PTA 33 PTD C/F 33/133	33 PTA 33 PTD C/F 33/133	33 PTA 33 PTD C/F 33/133	33 PTA 33 PTD C/F 33/133	33 PTA 33 PTD C/F 33/133	
Secondary Cyclone	33 PTA 33 PTD OM150 C/F 33/133	33 PTA 33 PTD OM150 C/F 33/133	33 PTA 33 PTD OM150 C/F 33/133	33 PTA 33 PTD OM150 C/F 33/133	33 PTA 33 PTD OM150 C/F 33/133	33 PTA 33 PTD OM150 C/F 33/133	33 PTA 33 PTD OM150 C/F 33/133	
Flotation Cell or Column	33 PTA C/F 33/133 OM150 DV*	33 PTA C/F 33/133 OM150 DV*	33 PTA C/F 33/133 OM150 DV*	33 PTA C/F 33/133 OM150 DV*	33 PTA C/F 33/133 OM150 DV*	33 PTA C/F 33/133 OM150 DV*	33 PTA C/F 33/133 OM150 DV*	
Thickener	33 PTD 33 PTA C/F 33/133	33 PTD 33 PTA C/F 33/133	33 PTD 33 PTA C/F 33/133	33 PTD 33 PTA C/F 33/133	33 PTD 33 PTA C/F 33/133	33 PTD 33 PTA C/F 33/133	33 PTD 33 PTA C/F 33/133	
Filter Pumps (vacuum or press)	33 PTA 33 PTD OM150 C/F 33/133	33 PTA 33 PTD OM150 C/F 33/133	33 PTA 33 PTD OM150 C/F 33/133	33 PTA 33 PTD OM150 C/F 33/133	33 PTA 33 PTD OM150 C/F 33/133	33 PTA 33 PTD OM150 C/F 33/133	33 PTA 33 PTD OM150 C/F 33/133	
Roaster / Autoclave	C67 OM157 PTD (low temp)	C67 OM157 PTD (low temp)				Chemical Plant Process		
Filter Pumps (vacuum or press)	C67 OM150	C67 OM150						
Leaching	DV CT	DV CT						
Tailing Thickener	33 PTA 33 PTD C/F 33/133	33 PTA 33 PTD C/F 33/133	33 PTA 33 PTD C/F 33/133	33 PTA 33 PTD C/F 33/133	33 PTA 33 PTD C/F 33/133			33 PTA 33 PTD C/F 33/133
Process Water	DV 33 PTD C67	DV 33 PTD C67	DV 33 PTD C67	DV 33 PTD C67	DV 33 PTD C67			DV 33 PTD C67
Tailings	33 PTD C/F 33/133	33 PTD C/F 33/133	33 PTD C/F 33/133	33 PTD C/F 33/133	33 PTD C/F 33/133			33 PTD C/F 33/133
Cyanide Extraction Plant (tailing)	C67 OM150 for higher pressure >270 psi	C67 OM150 for higher pressure >270 psi						
Electrowinning	DV	DV	DV	DV	DV		DV	

* For chemical addition

This guide is intended to be used as a general guide to mining valve application. Refer to the factory for specific recommendations based on actual service conditions.

Products

Every one of our Fabri-Valve slurry knife gate products is engineered to meet different mining operation needs. So you'll benefit from the superior performance and reduced downtime that only proper valve-to-process matching can provide.



ITT valves in mining provide less unscheduled maintenance downtime, improved plant performance and pipeline reliability and Safety for operators.

With 65 years of experience in knife gate valve design and manufacturing, you can trust ITT to ensure that you get exactly the right valve.



33 PTD

- Designed specifically for demanding light to medium slurry applications.
- For slurries ranging from dirty water to high-density settling slurries
- Self cleaning seats ensure consistent operation.
- When the valve is cycled from open to closed, the gate slides between the two seats and forms a seal to provide zero downstream leakage.
- Whether the valve is open or closed, the valve seats form a pressure boundary that is highly resistant to abrasive wear.
- This feature also allows the gate to be removed and replaced without taking the valve out of service.



33 PTA

- Sleeves are replaceable without disassembling the valve
- Sleeves are molded with an integral, fully encapsulated stiffener ring
- Full ported valve eliminates turbulence and has no metal parts in contact with flowing slurry
- Valve gate is completely withdrawn from the process flow when in the open position
- 100% factory tested for 100% bi-directional bubble tight shut-off
- No seat cavity where solids can collect.
- Engineered elastomer sleeves provide maximum performance and service life
- Stem cover available
- Open and closed lockout / tagout positions
- Gate wiper as standard



C/F 33/133

- Ported slide gate designed for difficult slurry applications
- The C/F 33 is unbonnetted and a discharging valve
- The C/F 133 version is bonnetted to provide redirected discharge and is our safest and most reliable slurry valve. It provides the most protection from high temp and corrosive media applications.
- Equipped with constant contact elastomer seats
- Provides bidirectional shut off from zero to full rated pressure.
- Design includes a high lubricity body liner or gate support ring (depending upon size) to prevent seat deterioration caused by excess hydraulic load.
- Unsurpassed performance in scaling application
- Available in sizes 2"-54".



C37

- C37 knife gate valves through 96" feature a heavy duty, rugged one-piece cast body chest and flanges (except 5", which is fabricated – F37).
- Sizes larger than 24" are fabricated from heavy plate.
- The Figure C/F37 is available in all stainless steel (designated "S") or with alloy steel wetted parts and carbon steel external parts (designated "R").
- In sizes 1.5" through 24", the "S" and the "R" share the same solid cast body.
- Sizes larger than 24" feature fabricated bodies configured to the service conditions.



C67

- Bi-directional Knife-Gate Valve
- Full port valve providing a bubble tight shut off in both directions, from zero to the full rated pressure.
- Used in water recovery systems
- Unique patented elastomer perimeter seat.
- The seat operates in a mode which insures positive shut off while controlling the effects of compression set to prolong the seat life.
- Available in sizes 2"-36" in stainless steel or ductile iron.



Cam-Tite® Ball Valve

- Top entry design, non-spherical ball.
- Positive sealing, low operating torque, blow-out proof stem, and the available "caged ball" option.
- Top entry design allows seat replacement without taking the valve from the pipeline.
- "Caged ball" option allows for quick repair or replacement of all internal components by simply unbolting the cover and lifting off the bonnet assembly.
- Available in various materials of construction, internal trims, end connections, and pressure ratings of up to ANSI class 600 lb, depending on size required.



Dia-Flo® Diaphragm Valve

- Diaphragm valves are the workhorses and foundation of ITT's valve product offerings.
- Engineered for tough work environments in the chemical processing, water treatment, pollution control, food and beverage, mining, pharmaceutical, pulp and paper, and power generation industries.
- Dependable, cost effective and versatile and is installed across the world in virtually every type of process plant.



XS150

- Robust perimeter seal that provides bi-directional bubble tight shutoff.
- ANSI Class 150 lb pressure temperature rating
- Unrestricted true flow port design
- Injectable packing feature allows for easy packing adjustments when valve is under pressure or inline
- Perimeter seal provides repeatable bi-directional bubble tight shut off
- Variety of body seat materials available for demanding applications



OM150

- Economical solution for abrasive and corrosive applications.
- No discharge of process media to the environment.
- Design utilizes the same superior sealing techniques as the XS150.
- Features a robust perimeter seal that provides bi-directional, bubbletight shutoff.
- Mechanically bonded urethane liners protect the body from abrasion and corrosion

Slurry Valve Decision Process

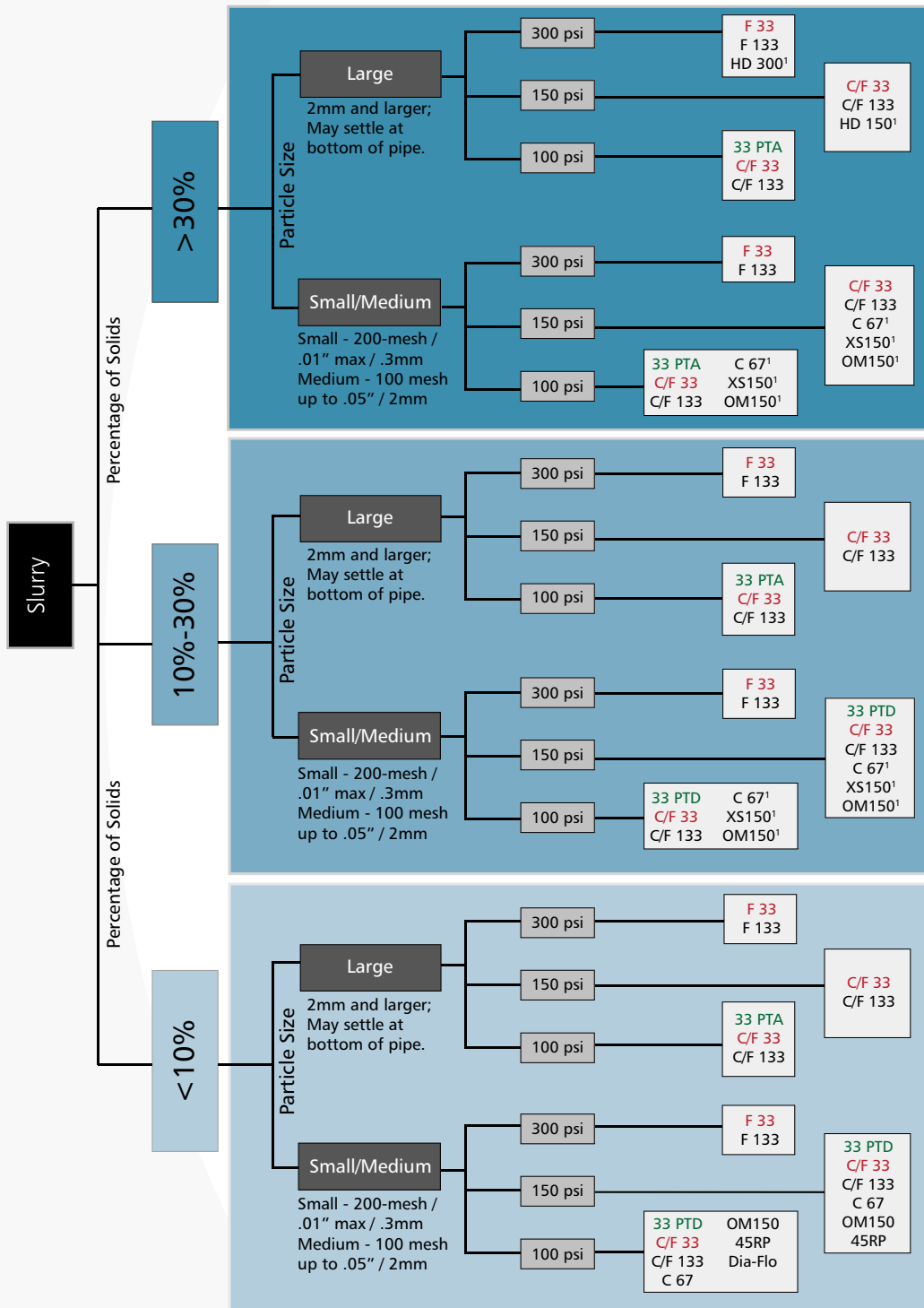

Key:

Can be used for Discharge and Non Discharge
 Discharging Only
 Non Discharging Only

SMALL PARTICULATE:
 200-mesh / .01in max / .3mm

MEDIUM PARTICULATE:
 100 mesh up to .05" / 2mm

LARGE PARTICULATE:
 2mm and larger, may settle at bottom of pipe.

Why Discharging Valves?

- Self Cleaning
 - Long Lasting
 - Low Cost
- Safety Precautions must be considered

Why Non-Discharging Valves?

- Environmental
- Safety from high temperatures and pressure

ITT's Vision and Values

ITT Corporation is a global company with a portfolio of highly-engineered products and solutions that serve all industrial segments including oil and gas, chemical and petrochemical, mining, power generation, and pulp and paper.

Be it pumps, valves and control systems, we strive to provide the best products and services to meet our customers' needs. Backed by our rich heritage of innovation for over 160 years, ITT Goulds Pumps has placed extraordinary focus on providing technical and commercial solutions that are innovative, reliable and safe.

Do the Right Thing - Always

Our business success is built on a solid foundation of our corporate vision and values. At ITT, we are firmly committed to doing the right thing always. We accomplish this through transparency in governance, a dedication to creating value with the right values, and fair competition in the marketplace. Grounded in our values of respect, responsibility and integrity, we expect our people, processes, policies and systems to be fair and accountable.

Environment, Safety & Health

ITT is proud to be a leader in protecting our employees, customers and the communities where we operate. The ITT Environment, Safety and Health Management System provides for the systematic control of environmental, safety and health (ESH) risks. Using this system, operational, administrative and cultural ESH processes are standardized and applied to continually improve environmental and occupational safety and health performance.

Eco-Footprint

ITT is acting to preserve and enhance our environment. We are striving to shrink our eco-footprint by further reducing the use of natural resources and hazardous materials in production, lowering emissions and cutting energy use in operations, and by improving product design.

Through our involvement in API-610 and its committees, we actively address and participate in the drive for increased safety, reliability and emissions containment in the oil and gas industry.



Visit our website at
www.engvalves.com



Engineered Valves, LLC
33 Centerville Road
Lancaster, PA 176031
717.509.2200
www.engvalves.com

Engineered Valves, LLC
1110 Bankhead Avenue
Amory, MS 38821
662.256.7185
www.engvalves.com

ITT Industries Ltd.
Weycroft Avenue,
Millwey Rise Industrial Estate
Axminster, EX13 5HU
United Kingdom
Tel: +44 1297-639100
Fax: +44 1297-630476

B.MiningValves.en-US.2017-06

© 2017 ITT Engineered Valves, LLC