



# Installation, Operation, and Maintenance Manual

33 PTD - Push Through Valve



**ITT**

ENGINEERED FOR LIFE



---





# Table of Contents

<b>Introduction and Safety</b> .....	2
Safety message levels .....	2
User health and safety .....	2
<b>Transportation and Storage</b> .....	4
Handling and unpacking guidelines .....	4
Lift the valve .....	4
Storage, disposal, and return requirements .....	5
<b>Product Description</b> .....	7
General description .....	7
<b>Installation</b> .....	8
Preinstallation .....	8
Install the valve .....	8
<b>Maintenance</b> .....	10
Precautions .....	10
Inspection .....	10
Lubrication requirements .....	10
Set the stroke .....	11
Replace the gate .....	11
Replace the gate support liner .....	11
Replace the seat .....	11
<b>Troubleshooting</b> .....	13
Knife gate valve operation troubleshooting .....	13
<b>Parts Listings and Cross-Sectionals</b> .....	14
Drawing and parts list .....	14

# Introduction and Safety

## Safety message levels

### Definitions

Safety message level	Indication
 <b>DANGER:</b>	A hazardous situation which, if not avoided, will result in death or serious injury
 <b>WARNING:</b>	A hazardous situation which, if not avoided, could result in death or serious injury
 <b>CAUTION:</b>	A hazardous situation which, if not avoided, could result in minor or moderate injury
 <b>Electrical Hazard:</b>	The possibility of electrical risks if instructions are not followed in a proper manner
<b>NOTICE:</b>	<ul style="list-style-type: none"> <li>• A potential situation which, if not avoided, could result in an undesirable result or state</li> <li>• A practice not related to personal injury</li> </ul>

## User health and safety

### General precautions

This product is designed and manufactured using good workmanship and materials, and meets all applicable industry standards. This product should be used only as recommended by an ITT engineer.



#### **WARNING:**

- Misapplication of the valve can result in injury or property damage. Select valves and valve components of the proper materials and make sure that they are consistent with your specific performance requirements. Incorrect application of this product includes but is not limited to:
  - Exceeding the pressure or temperature rating
  - Failing to maintain this product according to the recommendations
  - Using this product to contain or control media that is incompatible with the materials of construction
  - Proper containment or protection from hazardous media must be provided by the end user to protect employees and the environment from valve discharge.

### Qualifications and training

The personnel responsible for the assembly, operation, inspection, and maintenance of the valve must be appropriately qualified. The operating company must do the following tasks:

- Define the responsibilities and competency of all personnel handling this equipment.
- Provide instruction and training.

- Ensure that the contents of the operating instructions have been fully understood by the personnel.

Instruction and training can be carried out by either ITT or the reseller of the valve by order of the operating company.

### **Non-compliance risks**

Failure to comply with all safety precautions can result in the following conditions:

- Death or serious injury due to electrical, mechanical, and chemical influences
- Environmental damage due to the leakage of dangerous materials
- Product damage
- Property damage
- Loss of all claims for damages

### **Operational safety precautions**

Be aware of these safety precautions when operating this product:

- Do not leave hot or cold components of the product unsecured against contact if they are a source of danger.
- Do not remove the contact guard for moving parts when the product is in operation. Never operate the product without the contact guard installed.
- Do not hang items from the product. Any accessories must be firmly or permanently attached.
- Do not use the product as a step or hand hold.
- Do not paint over the identification tag, warnings, notices, or other identification marks associated with the product.

### **Maintenance safety precautions**

Be aware of these safety precautions when performing maintenance on this product:

- You must decontaminate the product if it has been exposed to harmful substances such as caustic chemicals.
- You must immediately fit or reactivate all safety and protective equipment upon completion of work.

### **Use of unauthorized parts**

Reconstruction or modification of the product is only permissible after consultation with ITT. Genuine spare parts and accessories authorized by ITT serve to maintain safety. Use of non-genuine ITT parts can annul liability of the manufacturer for the consequences. ITT parts are not to be used in conjunction with products not supplied by ITT as this improper use can annul all liability for the consequences.

### **Unacceptable modes of operation**

The operational reliability of this product is only guaranteed when it is used as designated. The operating limits given on the identification tag and in the data sheet may not be exceeded under any circumstances. If the identification tag is missing or worn, contact ITT for specific instructions.

# Transportation and Storage

## Handling and unpacking guidelines



**CAUTION:**

Always observe the applicable standards and regulations regarding the prevention of accidents when handling the product.

### Handling guidelines

Follow these guidelines when handling the product to prevent damage:

- Use care when handling the product.
- Leave protective caps and covers on the product until installation.

### Unpacking guidelines

Follow these guidelines when unpacking the product:

1. Inspect the package for damaged or missing items upon delivery.
2. Note any damaged or missing items on the receipt and freight bill.
3. If anything is out of order, file a claim with the shipping company.

## Lift the valve



**WARNING:**

Never tamper with the fasteners on the cylinder. Serious injury could result if the nuts on the cylinder tie rods are either tightened or loosened.



**CAUTION:**

- Personal injury or valve damage could occur if the valve is lifted by any part of the bevel gear assembly. The bevel gear assembly is not designed to support the weight of the valve.
- One person should not attempt to lift cylinder-operated valves larger than 6.00 in. (15.24 cm) or handwheel-operated valves larger than 12.00 in. (30.48 cm).
- Use lifting equipment rated for the weight of the valve assembly.
- Do not lift the valve by the handwheel.

1. Raise the valve into a vertical position.  
To lift larger valves, loop a lifting strap around one of the yoke legs.
2. If the valve is handwheel-operated, then turn the handwheel so that one spoke is aligned perpendicular to the flow direction (or parallel with the gate).
3. Prepare the valve for lifting:

If your valve is...	Then...
Handwheel-operated	Loop the lifting strap under the yoke. Take care that the lifting strap does not bind or tighten against any part of the handwheel. Refer to the Handwheel-operated valve figure below.
Bevel gear-operated	Loop the lifting strap(s) under the yoke. Refer to the Bevel gear-operated valve figure below.
Cylinder-operated	Attach two lifting eyes to the portion of the cylinder tie rods that extend above the top plate of the cylinder. Tie rod thread designations can be found in the Fabri-Valve GV Cylinder manual. Attach lifting hooks to the lifting eyes. Take care that all chains are free and not bound before you lift the valve. Refer to the Cylinder-operated valve figure below.

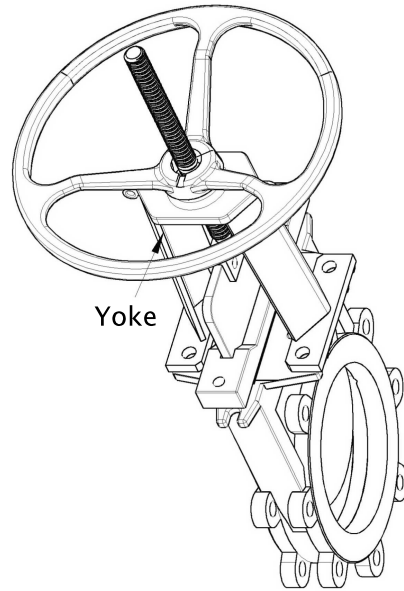

Figure 1: Handwheel-operated valve

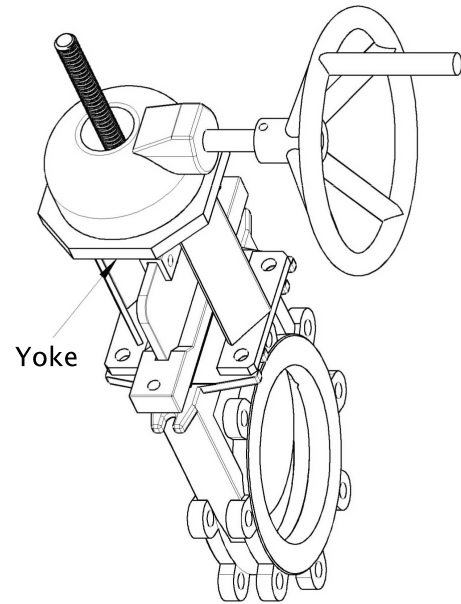

Figure 2: Bevel gear-operated valve

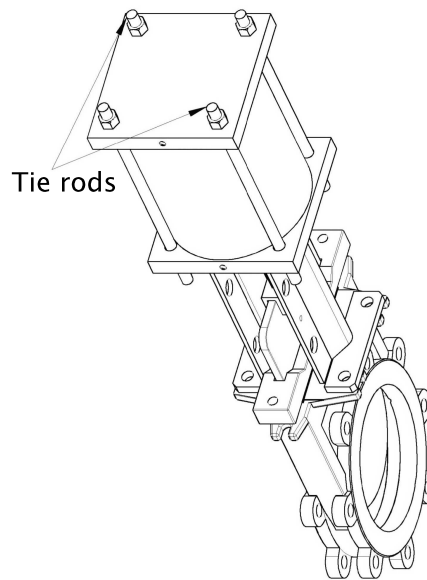

Figure 3: Cylinder-operated valve

4. Slowly take up the slack in the lifting straps to ensure that the straps are clear and not binding against the valve or valve top-works.



**WARNING:**

Do not adjust or remove the cylinder nuts. Cylinder failure may result from improperly tightened fasteners.

## Storage, disposal, and return requirements

### Storage

The package is designed to protect the valve only during shipping. If you are not installing the valve immediately after delivery, then you must store it according to these requirements.

**Table 1: Storage period**

This table describes requirements for short-term and long-term valve storage.

Storage period	Requirements
Less than 6 months	<ul style="list-style-type: none"> <li>• Do not expose the valve to direct sunlight.</li> <li>• Do not expose the valve to weather conditions.</li> <li>• Do not expose the valve to temperature extremes.</li> <li>• Do not stack the valves on top of each other.</li> <li>• Make sure the gate is in the full-open position.</li> </ul>
More than 6 months	<ul style="list-style-type: none"> <li>• Store in accordance with the short-term action items.</li> <li>• Store in accordance with ITT's Long Term Storage Procedure. Contact ITT to obtain this procedure.</li> </ul>

**Disposal**

Dispose of this product and associated components in compliance with federal, state, and local regulations.

**Return**

Ensure these requirements are met before you return a product to ITT:

- Contact ITT for specific instructions on how to return the product.
- Clean the valve of all hazardous material.
- Complete a Material Safety Data Sheet or Process Data Sheet for any process fluid that could remain on the valve.
- Obtain a Return Material Authorization from the factory.



# Product Description

## General description

### Design overview

The valve is a push-through style slurry valve that provides a robust solution for highly abrasive applications. This valve provides a continuous unrestricted rubber-lined flow path that is highly resistant to both abrasion and corrosion. Field replaceable rubber liners ensure minimal downtime for maintenance and repair.

Contact ITT to request a maintenance manual for another manufacturer's actuator, limit switch, positioner, controller, or other accessory.

### Features

This valve has the following features:

- The valve discharges a small amount of process substances during cycling. This clears the seat and chest areas of any build-up every time the valve is operated.
- The valve guides the gate smoothly through every stroke and protects the valve body from media contact with a high-density polyethylene liner in the chest cavities of the valve.

# Installation

## Preinstallation

### Precautions

---

**NOTICE:**

- Weld any flanges or pipelines before you install the valves. If this is impossible, protect the valve from excessive heat.
  - Remove all weld slag, rods, debris, and tools from the pipeline before valves are installed or cycled.
  - Always use studs in tapped holes to ensure full thread engagement of flange fasteners.
  - Do not over-tighten a machine bolt that has bottomed out. Valve damage may result, preventing proper operation.
  - Always use appropriate fasteners for the service, in compliance with applicable piping codes and standards.
- 

### Recommended fasteners

This table contains detailed information on the recommended fasteners for the valve.

Size, in (cm)	Size (DN)	Fastener diameter and thread	Total number of fasteners	Number of tapped holes in valve chest	Minimum stud bolt length, in (cm)	Minimum machine bolt length, in (cm)
2.00 (5.08)	50	5/8-11 UNC	8	8	2.313 (5.875)	1.313 (3.335)
3.00 (7.62)	80	5/8-11 UNC	8	8	2.75 (6.99)	1.50 (3.81)
4.00 (10.16)	100	5/8-11 UNC	16	16	2.75 (6.99)	1.50 (3.81)
6.00 (15.24)	150	3/4-10 UNC	16	16	3.00 (7.62)	1.50 (3.81)
8.00 (20.32)	200	3/4-10 UNC	16	16	3.25 (8.25)	2.00 (5.08)
10.00 (25.40)	250	7/8-9 UNC	24	24	3.50 (8.89)	2.00 (5.08)
12.00 (30.48)	300	7/8-9 UNC	24	16	3.75 (9.53)	2.25 (5.715)
14.00 (35.56)	350	1-8 UNC	24	16	4.00 (10.20)	2.50 (6.35)
16.00 (40.64)	400	1-8 UNC	32	24	4.00 (10.20)	2.50 (6.35)
18.00 (45.72)	450	1-1/8-7 UNC	32	24	4.50 (11.40)	2.75 (6.985)
20.00 (50.80)	500	1-1/8-7 UNC	40	32	5.00 (12.70)	2.75 (6.985)
24.00 (60.96)	600	1-1/4-7 UNC	40	32	5.50 (14.00)	3.00 (7.62)

### Acceptable leakage

Discharge of process media from this valve during cycling is normal. Discharge from the valve should cease when the valve is fully opened or fully closed. You can contain and direct normal valve discharge with an optional splash guard.

### Excessive leakage

There are no adjustments to be made on this valve if it is leaking. Refer to the Troubleshooting chapter for tips on handling a leaking valve.

## Install the valve

Determine the required torque necessary to tighten the fasteners by considering the type of gasket (if used), line pressure, bolt material, and lubrication.

1. Place the valve in the open position.  
This will reduce the interference of the seats with the mating flanges during installation.
2. Ensure that the yoke is properly supported.

If the valve is greater than 24 in. (60.96 cm) or has either electric or non-standard operator period, then the valve may require external support of the yoke assembly. Contact ITT for advice on the installation of valves with non-standard operators.

3. If you install a valve with an actuator in a horizontal position, then you may need to support the actuator. Consult ITT for technical advice.
4. Bolt the valve to the mating flange using the proper size fasteners. See the Recommended fasteners table in this section.
  - a) Lubricate stainless steel fasteners to prevent galling.
  - b) Adjust fastener length to adjust for mating flange thickness, gaskets, and support rings.
5. Tighten the flange bolts in an alternating sequence. Torques are listed in the Recommended Fasteners table in [Preinstallation](#) (page 8)

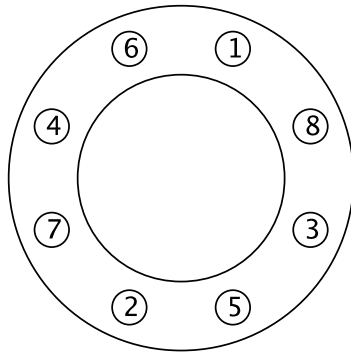

6. Prepare the valve for hydrotesting:

If your valve is ...	Then ...
Handwheel-operated or Bevel gear-operated	Requires no further action
Air Cylinder-operated	Connect control air supply to the air cylinder (standard configured valve required pressure is 60–100 psi)
Hydraulic Cylinder-operated	Connect control hydraulic supply to the hydraulic cylinder (standard configured valve required pressure is 600–1000 psi)
Electric-operated	Connect electric supply according to manufacturers instructions

7. Hydrotest the system.
8. If the valve is leaking, then replace the seat. For more information, see [Replace the seat](#) (page 11)

# Maintenance

## Precautions

**WARNING:**

- All procedures must be performed by qualified personnel.
- When the process fluid is hazardous, thermal (hot or cold), or corrosive, take extra precautions. Employ the appropriate safety devices and be prepared to control a process media leak.
- Always wear protective clothing and equipment to safeguard the eyes, face, hands, skin, and lungs from the particular fluid in the line.

**CAUTION:**

- Disconnect electrical, pneumatic, and hydraulic power before servicing actuator or automation components.

**NOTICE:**

Make sure that travel limits are set for both open and closed positions on electrically operated valves.

## Inspection

Inspection area	What to look for	Action if problem is found
External valve parts	Excessive wear or corrosion	<ul style="list-style-type: none"> <li>• Replace the affected parts</li> <li>• Contact ITT to obtain replacement parts or for specific instructions</li> </ul>

## Lubrication requirements

### Lubrication schedule

The stem, stem nut, seats, and gate of the knife gate valve are lubricated at the factory before shipment.

Lubricate the stem and stem nut periodically to prevent wear and to minimize operating forces. Lubrication of the seats and gates is not required under normal operation. The seats and gate should be lubricated upon each seat replacement (see [Replace the seat](#) (page 11)).

### Acceptable lubricants

Lubricants are for the stem and stem nut.

Brand	Lubricant type
Chevron	Industrial Grease-Medium
Fel-Pro	C5-A Compound
Moly	XL 47-F2-75
Texaco	Molytex Grease #2

## Acceptable silicone based lubricants for the gate and seat

### NOTICE:

Use only silicone based lubricants on the seats and gate. Petroleum based lubricants will damage the seats and shorten the life of the valve.

Brand	Lubricant type
Dow Corning	Dow 111
Dow Corning	Dow 44
GE	Compound G661

## Set the stroke

1. If the valve is bevel gear-actuated, adjust the top stroke limiter so that the valve closes enough to allow the lockout pin to pass through both holes in the yoke.  
This is the proper closed position.
2. If the valve is cylinder-actuated, follow these steps:
  - a) Close the valve.
  - b) Adjust the valve stroke by screwing the gate clamp in or out of the cylinder rod.  
The valve stroke is set when the bottom holes in the yoke align with the hole in the top of the gate.
  - c) Install the gate clamp nut(s) on the bolt(s) and tighten.
  - d) Tighten the jam nut against the cylinder rod.

## Replace the gate

This valve is designed to allow replacement of the gate without removing the valve from service.

1. Ensure that the valve is in the open position.
2. Disconnect the actuator from the energy source.
3. Support the weight of the actuator using lifting eyes or a strap.
4. Remove the bolts securing the actuator or handwheel adapter.
5. Lift the gate from the valve along with the actuator or handwheel.
6. Replace the gate.
7. Reassemble the valve and actuator.

## Replace the gate support liner

1. Isolate the valve from service.
2. Place the valve in the fully open position.
3. Remove the entire valve from the pipeline.
4. Disassemble the valve.
5. Replace the polymer valve liner.  
The recess for the packing must be at the top of the valve.
6. Reassemble the valve while ensuring that the ports in the liners are aligned with the ports in the valve flanges.

## Replace the seat

1. Isolate the valve from service.
2. Place the valve in the fully open position.
3. Remove the entire valve from the pipeline.

4. Remove the seats from the outside of the valve.  
There is no need to disassemble the valve body.
5. Examine the leading edge of the gate for burrs or marring that could damage the seats.
6. If the gate is damaged, remove and repair the gate.  
For more information, see [Replace the gate](#) (page 11).
7. Lubricate the seat with silicone lubricant as shown below.

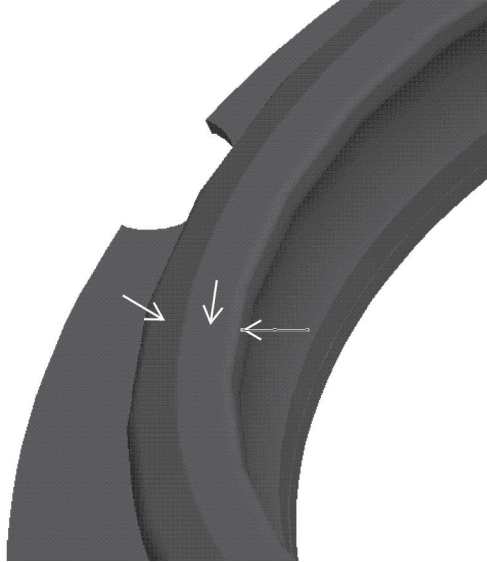

For more information, see [Lubrication requirements](#) (page 10).

8. Lubricate the leading edge of the gate with silicone lubricant.  
For more information, see [Lubrication requirements](#) (page 10).

---

# Troubleshooting

## Knife gate valve operation troubleshooting

Symptom	Cause	Remedy
The fully-opened or fully-closed valve is leaking.	The upstream seat may be damaged.	Replace the seat with a genuine ITT replacement seat.
Excessive force is required to open and close the valve.	The valve is not lubricated properly.	See Lubrication requirements in the Maintenance section.

# Parts Listings and Cross-Sectionals

## Drawing and parts list

### List of parts

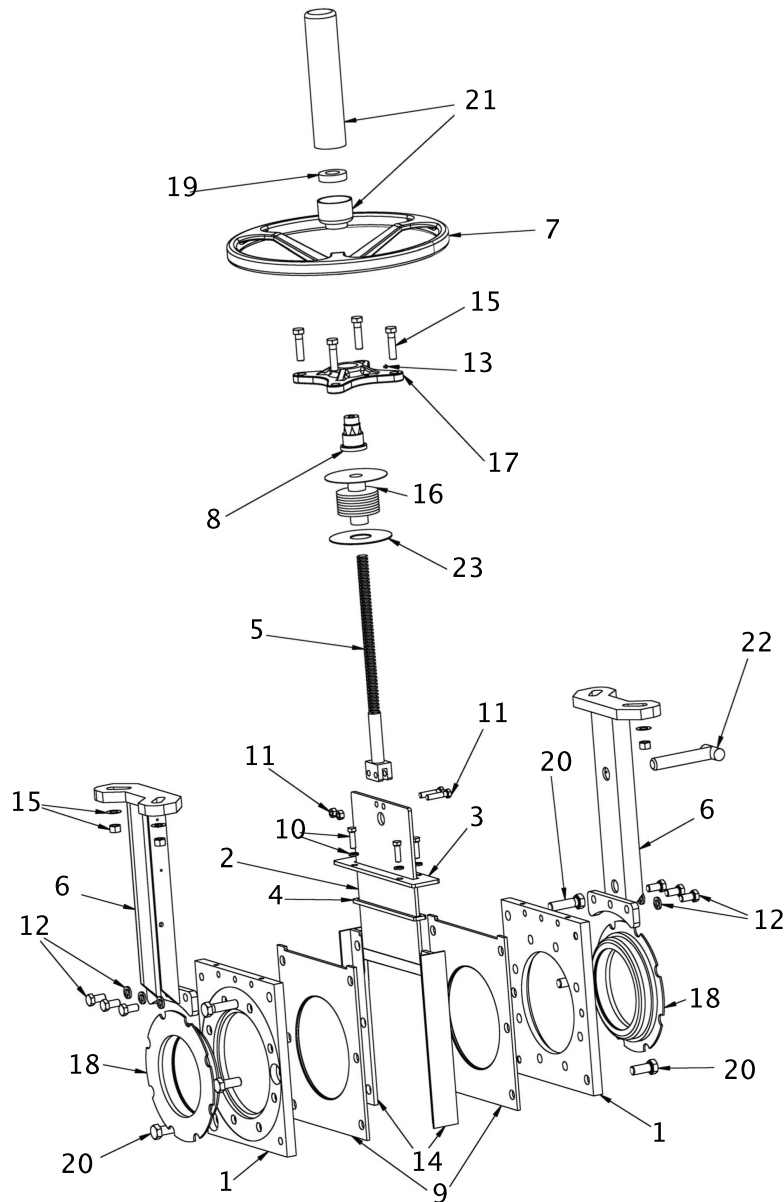

Figure 4:

Item	Description	Material	Quantity
1	Body	Mild steel	2
2	Gate	316 Stainless steel	1
3	Packing gland	Mild steel	1
4	Packing	Acrylic silicone	As required
5	Stem assembly	304 Stainless steel	1
6	Yoke	Mild steel	2
7	Handwheel	Ductile iron	1
8	Stem nut	Bronze	1



Item	Description	Material	Quantity
9	Gate support liner	UHMW	2
10	Packing gland fasteners	Plated steel	As required
11	Gate fasteners	Plated steel	As required
12	Yoke fasteners	Plated steel	4
13	Grease fitting	Plated steel	Optional
14	Body spacer	Mild steel	2
15	Yoke hub fasteners	Plated steel	As required
16	Rod boot	Nylon	1
17	Yoke hub	Mild steel	1
18 <sup>1</sup>	Seat with load ring	Natural Rubber	2
19	Stop nut	Carbon steel	1
20	Body fasteners	Stainless steel	As required
21	Stem cover	Mild steel	1
22	Lock pin	17-4 Stainless steel	1
23	Rod boot support plate	Stainless steel	1

---

<sup>1</sup> Recommended spare part

Visit our website for the latest version of this document and more information:

[www.engvalves.com](http://www.engvalves.com)



ENGINEERED FOR LIFE

Engineered Valves  
1110 Bankhead Avenue  
Amory, MS 38821  
USA  
Tel. +1-662-256-7185  
Fax +1-662-256-7932  
E-mail: [engvalves.custserv@itt.com](mailto:engvalves.custserv@itt.com)