

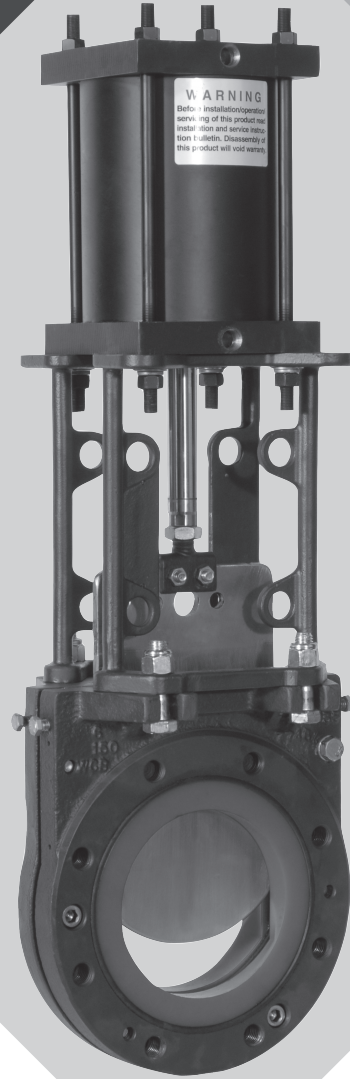

Installation, Operation, and Maintenance Manual

XS150-ULV Urethane Lined Knife Gate Valve



ITT

ENGINEERED FOR LIFE





Table of Contents

Introduction and Safety	2
Safety message levels	2
User health and safety	2
Transportation and Storage	4
Handling and unpacking guidelines	4
Lift the valve	4
Storage, disposal, and return requirements	5
Product Description	7
General description	7
Identification tag	8
Installation	9
Preinstallation	9
Install the valve	10
Maintenance	12
Precautions	12
Inspection	12
Lubrication requirements	12
Adjust the packing	12
Add the packing	13
Replace the main seal	13
Set the stroke	15
Troubleshooting	18
Knife gate valve operation troubleshooting	18
Parts Listings and Cross-Sectionals	19
Drawing and parts list	19

Introduction and Safety

Safety message levels

Definitions

Safety message level	Indication
 DANGER:	A hazardous situation which, if not avoided, will result in death or serious injury
 WARNING:	A hazardous situation which, if not avoided, could result in death or serious injury
 CAUTION:	A hazardous situation which, if not avoided, could result in minor or moderate injury
 Electrical Hazard:	The possibility of electrical risks if instructions are not followed in a proper manner
NOTICE:	<ul style="list-style-type: none"> • A potential situation which, if not avoided, could result in an undesirable result or state • A practice not related to personal injury

User health and safety

General precautions

This product is designed and manufactured using good workmanship and materials, and meets all applicable industry standards. This product should be used only as recommended by an ITT engineer.



WARNING:

- Misapplication of the valve can result in injury or property damage. Select valves and valve components of the proper materials and make sure that they are consistent with your specific performance requirements. Incorrect application of this product includes but is not limited to:
 - Exceeding the pressure or temperature rating
 - Failing to maintain this product according to the recommendations
 - Using this product to contain or control media that is incompatible with the materials of construction
 - Proper containment or protection from hazardous media must be provided by the end user to protect employees and the environment from valve discharge.

Qualifications and training

The personnel responsible for the assembly, operation, inspection, and maintenance of the valve must be appropriately qualified. The operating company must do the following tasks:

- Define the responsibilities and competency of all personnel handling this equipment.
- Provide instruction and training.

- Ensure that the contents of the operating instructions have been fully understood by the personnel.

Instruction and training can be carried out by either ITT or the reseller of the valve by order of the operating company.

Non-compliance risks

Failure to comply with all safety precautions can result in the following conditions:

- Death or serious injury due to electrical, mechanical, and chemical influences
- Environmental damage due to the leakage of dangerous materials
- Product damage
- Property damage
- Loss of all claims for damages

Operational safety precautions

Be aware of these safety precautions when operating this product:

- Do not leave hot or cold components of the product unsecured against contact if they are a source of danger.
- Do not remove the contact guard for moving parts when the product is in operation. Never operate the product without the contact guard installed.
- Do not hang items from the product. Any accessories must be firmly or permanently attached.
- Do not use the product as a step or hand hold.
- Do not paint over the identification tag, warnings, notices, or other identification marks associated with the product.

Maintenance safety precautions

Be aware of these safety precautions when performing maintenance on this product:

- You must decontaminate the product if it has been exposed to harmful substances such as caustic chemicals.
- You must immediately fit or reactivate all safety and protective equipment upon completion of work.
- You must use the appropriate lock-out procedures to isolate the valve from all power sources before performing maintenance on externally actuated valves.

Use of unauthorized parts

Reconstruction or modification of the product is only permissible after consultation with ITT. Genuine spare parts and accessories authorized by ITT serve to maintain safety. Use of non-genuine ITT parts can annul liability of the manufacturer for the consequences. ITT parts are not to be used in conjunction with products not supplied by ITT as this improper use can annul all liability for the consequences.

Unacceptable modes of operation

The operational reliability of this product is only guaranteed when it is used as designated. The operating limits given on the identification tag and in the data sheet may not be exceeded under any circumstances. If the identification tag is missing or worn, contact ITT for specific instructions.

Transportation and Storage

Handling and unpacking guidelines



CAUTION:

Always observe the applicable standards and regulations regarding the prevention of accidents when handling the product.

Handling guidelines

Follow these guidelines when handling the product to prevent damage:

- Use care when handling the product.
- Leave protective caps and covers on the product until installation.

Unpacking guidelines

Follow these guidelines when unpacking the product:

1. Inspect the package for damaged or missing items upon delivery.
2. Note any damaged or missing items on the receipt and freight bill.
3. If anything is out of order, file a claim with the shipping company.

Lift the valve



WARNING:

Never tamper with the fasteners on the cylinder. Serious injury could result if the nuts on the cylinder tie rods are either tightened or loosened.



CAUTION:

- Personal injury or valve damage could occur if the valve is lifted by any part of the bevel gear assembly. The bevel gear assembly is not designed to support the weight of the valve.
- One person should not attempt to lift cylinder-operated valves larger than 6.00 in. (15.24 cm) or handwheel-operated valves larger than 12.00 in. (30.48 cm).
- Use lifting equipment rated for the weight of the valve assembly.
- Do not lift the valve by the handwheel.

1. Raise the valve into a vertical position.
To lift larger valves, loop a lifting strap around one of the yoke legs.
2. Prepare the valve for lifting:

If your valve is...	Then...
Handwheel-operated	Loop the lifting strap under the yoke. Take care that the lifting strap does not bind or tighten against any part of the handwheel. Refer to the Handwheel-operated valve figure below.
Bevel gear-operated	Loop the lifting strap(s) under the yoke. Refer to the Bevel gear-operated valve figure below.
Cylinder-operated	Attach two lifting eyes to the portion of the cylinder tie rods that extend above the top plate of the cylinder. Tie rod thread designations can be found in the Fabri-Valve GV Cylinder manual. Attach lifting hooks to the lifting eyes. Take care that all chains are free and not bound before you lift the valve. Refer to the Cylinder-operated valve figure below.

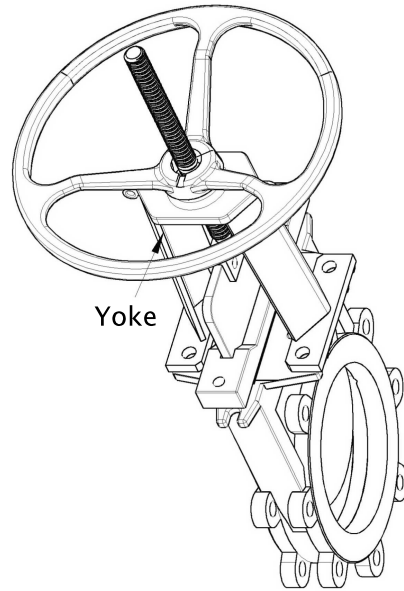

Figure 1: Handwheel-operated valve

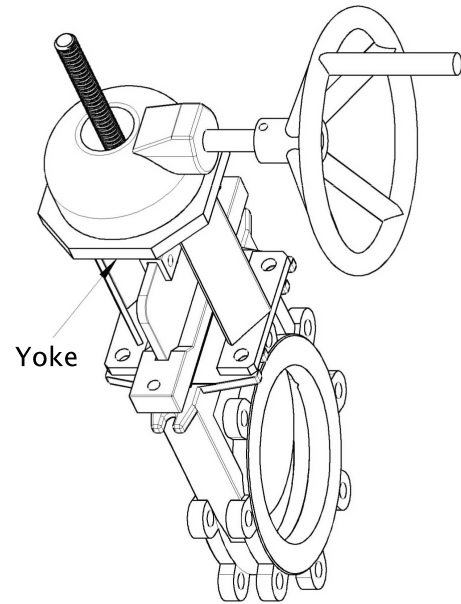

Figure 2: Bevel gear-operated valve

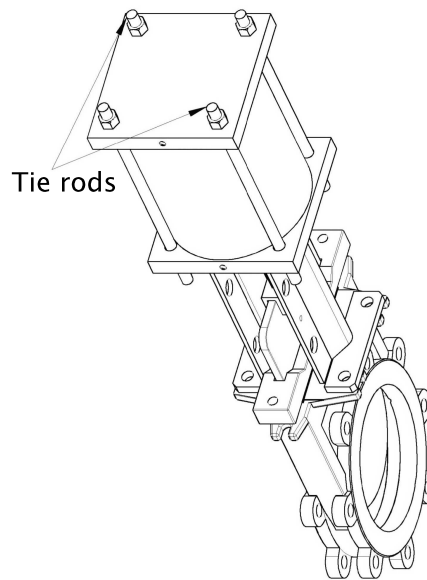

Figure 3: Cylinder-operated valve

3. Slowly take up the slack in the lifting straps to ensure that the straps are clear and not binding against the valve or valve top-works.



WARNING:

Do not adjust or remove the cylinder nuts. Cylinder failure may result from improperly tightened fasteners.

Storage, disposal, and return requirements

Storage

The package is designed to protect the valve only during shipping. If you are not installing the valve immediately after delivery, then you must store it according to these requirements.

Table 1: Storage period

This table describes requirements for short-term and long-term valve storage.

Storage period	Requirements
Less than 6 months	<ul style="list-style-type: none"> • Do not expose the valve to direct sunlight. • Do not expose the valve to weather conditions. • Do not expose the valve to temperature extremes. • Do not stack the valves on top of each other. • Make sure the gate is in the full-open position.
More than 6 months	<ul style="list-style-type: none"> • Store in accordance with the short-term action items. • Store in accordance with ITT's Long Term Storage Procedure. Contact ITT to obtain this procedure.

Disposal

Dispose of this product and associated components in compliance with federal, state, and local regulations.

Return

Ensure these requirements are met before you return a product to ITT:

- Contact ITT for specific instructions on how to return the product.
- Clean the valve of all hazardous material.
- Complete a Material Safety Data Sheet or Process Data Sheet for any process fluid that could remain on the valve.
- Obtain a Return Material Authorization from the factory.

Product Description

General description

Design overview

The valve features a robust perimeter seal that provides bidirectional bubble tight shutoff. The perimeter seal is double-locked in the valve body to securely retain the perimeter seal in the seal groove even during the most demanding applications.

Contact ITT to request a maintenance manual for another manufacturer's actuator, limit switch, positioner, controller, or other accessory.

Features

- The seal groove is specially designed to prevent seal pullout but also allows the seal to move and prevent over-compression.
- The perimeter seal has shoulders, which mechanically retain (lock) the seal in the seal groove.
- The seal's tab feature acts as the body joint seal and as a secondary lock preventing seal pullout.
- Replaceable FV8000 urethane liners protect the body from abrasion and corrosion.

Seal and seat description

- Main seal: The main seal is the part comprised of the valve seat and chest seal. Throughout this manual the term seat and seal are both used to describe the main seal.
- Valve seat: When the valve is closed, the gate and the seat form a bidirectional, bubble-tight seal.
- Chest seal: Whether the valve is open or closed, the chest seal prevents fluid from leaking out the top of the valve through the gate opening. The chest seal can be adjusted by tightening the packing bolts or by adding additional packing as required.
- Liner: The liner protects the perimeter seal from the abrasion of direct process flow.

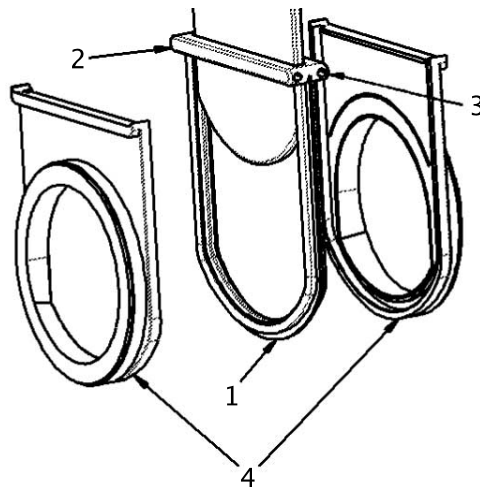

1. Valve seat
2. Chest seal
3. Injectible packing
4. Liner

Figure 4: Main seal

Identification tag

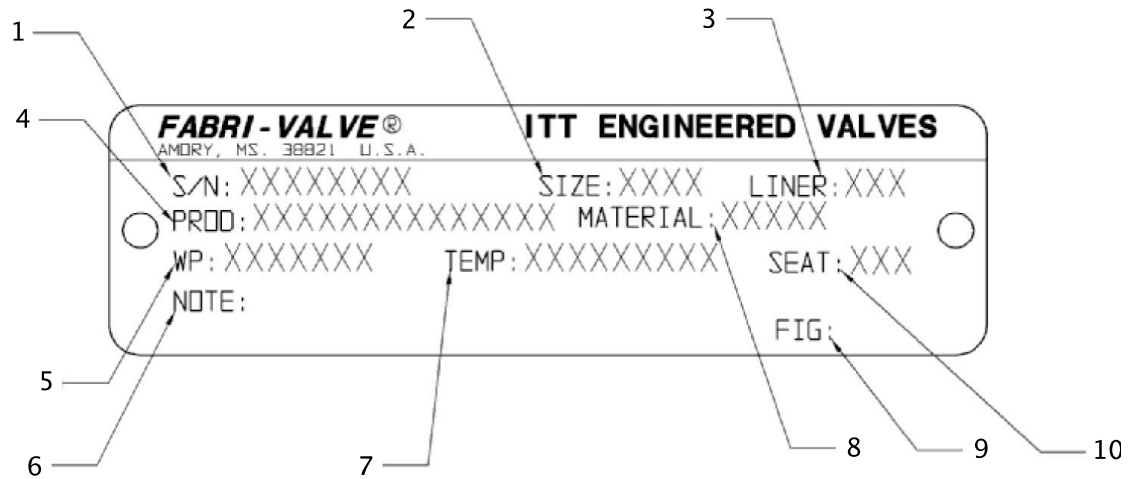

1. Serial number
2. Nominal valve size
3. Liner material code
4. Product code
5. Maximum working pressure
6. Special notes or instructions¹
7. Temperature range
8. Body material code
9. Figure number (model number)
10. Seat material code

¹ Only applicable for some valve types.

Installation

Preinstallation

Precautions



WARNING:

- Air cylinders, when provided, are sized for a specified input pressure. Excessive pressure could result in serious personal injury or may cause damage to the valve and cylinder. Air regulators and air filters are available from your ITT distributor.
- Do not use a valve at service conditions that exceed the rating on the identification tag.
- Always depressurize the line and drain the system fluid before you open a pipeline.
- Always wear protective clothing and equipment to safeguard the eyes, face, hands, skin, and lungs from the particular fluid in the line.

NOTICE:

- Weld any flanges or pipelines before you install the valves. If this is impossible, protect the valve from excessive heat.
- Remove all weld slag, rods, debris, and tools from the pipeline before valves are installed or cycled.
- Always use studs in tapped holes to ensure full thread engagement of flange fasteners.
- Do not override the closed position stop. Seat damage and leakage may result.
- Do not install a 14-24 in. valve in a horizontal pipe with the stem horizontal. The packing seal will experience excessive wear in this position.
- Do not over-tighten a machine bolt that has bottomed out. Valve damage may result, preventing proper operation.
- Always use appropriate fasteners for the service, in compliance with applicable piping codes and standards.

Recommended Installation Details

Flat Faced XS150-ULV²		
Piping Flange Connection Type	Recommended Installation without Flange Gasket	With Compressed Flange Gaskets (not recommended)
Metal raised face pipe flanges	Load distribution rings are not required	Load distribution rings are required for proper installation
Metal flat faced pipe flanges	Load distribution rings are not required	Load distribution rings are required for proper installation. Gasket must be full face.
Rubber lined flat face flanges	Load distribution rings are required for proper installation	Load distribution rings are required for proper installation. Gasket must be full face.
Fiberglass or plastic flat faced flanges ³	Load distribution rings are not required	Load distribution rings are required for proper installation. Gasket must be full face.

² Consult the factory for installation guidelines for XS150-ULV configurations that have valve body flange connections other than flat face.

³ Consult with the fiberglass or plastic flange manufacturer to determine if support rings are required for use with raised faced flanges.

Recommended fasteners

Valve size (inches)	Valve size (DN)	Fastener diameter and thread	Total number of fasteners	Number of tapped holes in valve chest	Minimum stud length, inches (millimeters)
2	50	5/8-11 UNC	8	4	3.25 (82.5)
3	80	5/8-11 UNC	8	4	3.75 (95.3)
4	100	5/8-11 UNC	16	4	3.75 (95.3)
5	125	3/4-10 UNC	16	4	3.75 (95.3)
6	150	3/4-10 UNC	16	4	3.75 (95.3)
8	200	3/4-10 UNC	16	4	4.25 (108.0)
10	250	7/8-9 UNC	24	8	4.75 (120.7)
12	300	7/8-9 UNC	24	8	4.75 (120.7)
14	350	1-8 UNC	24	8	5.25 (133.4)
16	400	1-8 UNC	32	12	5.50 (140.0)
18	450	1-1/8-7 UNC	32	12	6.00 (152.4)
20	500	1-1/8-7 UNC	40	16	6.25 (158.8)
24	600	1-1/4-7 UNC	40	16	7.00 (177.8)

Install the valve

Determine the required torque necessary to tighten the fasteners by considering the type of gasket, line pressure, bolt material, and lubrication.

1. If you install a valve with an actuator in a horizontal position, then you may need to support the actuator. Consult ITT for technical advice.
2. Bolt the valve to the mating flange using the proper size fasteners. See the Recommended fasteners table in this section. ITT recommends you use studs to ensure the full thread engagement of tapped holes.
 - a) Lubricate stainless steel fasteners to prevent galling.
 - b) Adjust fastener length to adjust for mating flange thickness, gaskets, and support rings.
3. Tighten the flange bolts in an alternating sequence. Torques are listed in the Recommended Fasteners table in [Preinstallation](#) (page 9)

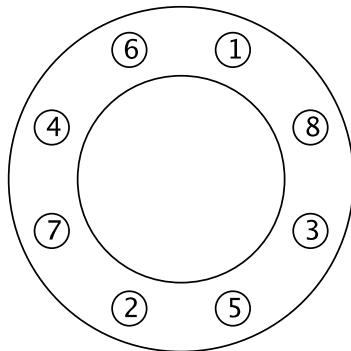

4. Prepare the valve for hydrotesting:

If your valve is ...	Then ...
Handwheel-operated or Bevel gear-operated	Requires no further action
Air Cylinder-operated	Connect control air supply to the air cylinder (standard configured valve required pressure is 60–100 psi)
Hydraulic Cylinder-operated	Connect control hydraulic supply to the hydraulic cylinder (standard configured valve required pressure is 600–1000 psi)
Electric-operated	Connect electric supply according to manufacturers instructions

5. Hydrotest the system.
6. If the valve is leaking, then Adjust the packing.

For more information, see Adjust the packing in the Maintenance section.

Maintenance

Precautions

WARNING:

- All procedures must be performed by qualified personnel.
- When the process fluid is hazardous, thermal (hot or cold), or corrosive, take extra precautions. Employ the appropriate safety devices and be prepared to control a process media leak.
- Always wear protective clothing and equipment to safeguard the eyes, face, hands, skin, and lungs from the particular fluid in the line.

CAUTION:

- Disconnect electrical, pneumatic, and hydraulic power before servicing actuator or automation components.

NOTICE:

Make sure that travel limits are set for both open and closed positions on electrically operated valves.

Inspection

Inspection area	What to look for	Action if problem is found
External valve parts	Excessive wear or corrosion	<ul style="list-style-type: none"> • Replace the affected parts • Contact ITT to obtain replacement parts or for specific instructions
Injectable packing bolts	Leakage	Replace the main seal.

Lubrication requirements

Lubrication schedule

The stem and stem nut of the knife gate valve are lubricated at the factory before shipment. Lubricate the stem and stem nut periodically to prevent wear and to minimize operating forces.

Acceptable lubricants

Brand	Lubricant type
Chevron	Industrial Grease-Medium
Fel-Pro	C5-A Compound
Moly	XL 47-F2-75
Texaco	Molytex Grease #2

Adjust the packing

1. Identify the location of the packing leak.
2. Slowly tighten the injectable packing bolt that is closest to the leak by screwing it clockwise one revolution. Tighten in small increments until the leak stops.
3. If the injectable packing bolts are completely screwed into the body, then add the packing. For more information, see [Add the packing](#) (page 13).
4. Actuate the valve to move the gate 0.50 to 1.00 in. (12.7 to 25.4 mm) in either direction.

5. If the packing is still leaking, then repeat the steps above.

Add the packing



WARNING:

Always wear protective clothing and equipment to safeguard the eyes, face, hands, skin, and lungs from the particular fluid in the line.

You will need a simple re-packing tool to add the packing. This tool can be fabricated at the job site, have a 0.21 in. (5.3 mm) diameter, and be at least 5 in. (127 mm) long.

1. If the fluid is dangerous, lethal, harmful, active, scorching, or under high pressure, then depressurize the pipeline.
2. Remove the injectable packing bolt:



CAUTION:

Beware of leakage past the injectable packing bolts. If you see this leakage, then quickly screw the injectable packing bolt back to its full depth and replace the main seal.

NOTICE:

Do not over-tighten the injectable packing bolt. This could lead to premature failure due to wear against the gate.

- a) If you see leakage past the injectable packing bolts, then quickly screw the injectable packing bolt back to its full depth and depressurize the line for maintenance.
- b) When the line is depressurized, slowly remove the injectable packing bolt.
3. Insert small amounts of injectable packing:
 - a) Place the packing in the hole.
Leave enough room in the hole so you can screw the injectable packing bolt back in.
 - b) Slowly push the packing into the valve with the re-packing tool.
4. Replace the injectable packing bolt and tighten it until it is finger tight.
5. Check the chest seal for leaks:
 - a) Tighten the injectable packing bolt clockwise one revolution.
 - b) If the packing is leaking, then tighten the packing screws in small increments until the leak stops.
For more information, see [Adjust the packing](#) (page 12).

Replace the main seal



CAUTION:

Always secure the valve to a fixture, workbench, or table that is anchored to the floor. An overhead hoist is helpful for large valves.

1. Disassemble the valve assembly:
 - a) Remove the valve assembly from the pipeline and secure it in the vertical position.
 - b) Remove the yoke fasteners and gate clamp fasteners.
 - c) Lift off the yoke and topworks from the valve.
 - d) Set the valve on a workbench.
 - e) Remove the body clamping bolts on both sides of the valve.
 - f) Lift out the gate, clean it, and smooth out any marred or rough surfaces with a scotch-brite pad.
The gate should be free of grooves and scratches.

- g) Remove the liner-seal assembly and separate the urethane liners.
The body halves will now be separated.
- 2. Replace the main seal:
 - a) Remove the main seal.
 - b) Clean the body interior.
 - c) Inspect the body interior for damage or abnormalities and smooth out any sharp edges.
 - d) Press the new main seal into the grooves of one liner half.
There is no specific upstream or downstream orientation for the main seal.
 - e) Match the main seal groove of the remaining liner half with the main seal and press the liners together.
There will be a small gap between the liners. The outboard tab will seal this gap.
 - f) Place the liner-seal assembly in one of the body halves.
If the fit is tight, then you may need a soft blow hammer to properly seat the assembly in the body.
- 3. Join together the two body halves:
 - a) Line up the bottom edge of the two body halves with the bottom of the liner and main seal assembly.
 - b) Slowly press body halves together.
 - c) Inspect the liner and main seal assembly to make sure it has properly seated in the mating grooves of both body halves.
 - d) Lubricate the body bolts with anti-seize or an equivalent lubricant.
 - e) Insert the body bolts into the bolt holes and engage approximately one thread on each bolt.
Do not tighten the body bolts at this time.
- 4. Apply a silicone lubricant to the leading edges and both faces of the gate.

NOTICE:

Always use a lubricant compatible with the pumped fluid.

- 5. Insert the gate through the top of the valve until the gate tip is even with the top of the valve port.

NOTICE:

The gate should slide easily into the main seal. If excessive resistance is met, determine the cause before continuing the gate installation. Failure to do this may result in damage to the main seal.

- 6. Tighten the body bolts in an alternating sequence to ensure even compression of the main seal.
- 7. Reassemble the valve assembly:
 - a) Secure the valve in the vertical position and reinstall the yoke and topworks.
 - b) Reconnect the topworks.

If the topworks is a ...	Then ...
Handwheel	Reconnect the non-rising stem nut to the gate with the non-rising stem nut fasteners.
Cylinder	Insert the gate clamp bolts through the gate clamp and set the stroke.
Bevel gear	Reconnect the gate clamp to the gate with the gate clamp fasteners and set the stroke.

For more information, see [Set the stroke](#) (page 15).

- 8. Add packing to the valve.
For more information, see [Add the packing](#) (page 13).
- 9. Replace the two O-ring seals on the flange faces and glue the O-ring in place with a bonding agent such as Loctite 380.

10. After the valve is installed and pressurized to operating pressure, adjust the injectable packing.
For more information, see [Adjust the packing](#) (page 12).

Set the stroke

NOTICE:

- Do not over-compress the seal.
- Always adjust the closed position properly. Improper adjustment may cause leakage, damage, or premature failure of the seal.

1. Is the valve handwheel-actuated?
 - If no: Proceed to step 2.
 - If yes: No adjustment is necessary. The stroke is set at the factory.
2. Is the valve bevel gear-actuated?
 - If no: Proceed to step 3.
 - If yes: Follow the steps below:
 - a) Loosen the two bolts in the top stop nut (1).

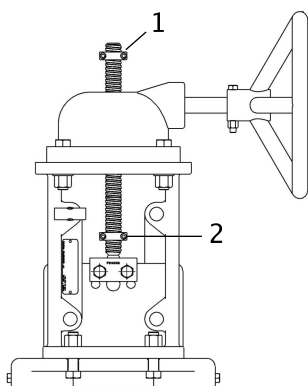

1. Top stop nut
2. Bottom stop nut

- b) Close the valve until a 0.005 in. (0.013 cm) shim or piece of paper can not move between the gate and the seal freely.
- c) Adjust the top stop nut until it stops against the bevel gear actuator.
- d) Open the valve until the top stop nut can be viewed above the bevel gear actuator.
- e) Move the stop nut up by the adjustment distance for the valve size.

Valve size	Adjustment distance
2–4 in. (50–100 DN)	0.06 in. (1.5 mm)
6–24 in. (150–600 DN)	0.13 in. (3.3 mm)

- f) Tighten the two bolts in the top stop nut to lock it in place.
 - g) Loosen the two bolts in the bottom stop nut (2).
 - h) Open the valve until the gate clears the waterway by 0–0.13 in. (0–3.3 mm).
 - i) Adjust the bottom stop nut until it stops against the bevel gear actuator.
 - j) Tighten the two bolts in the bottom stop nut to lock it in place.
3. Is the valve cylinder-actuated?
 - If no: Consult the factory for instructions on other actuation.
 - If yes: Follow the steps below:

- a) Loosen the gate clamp jam nut (1).

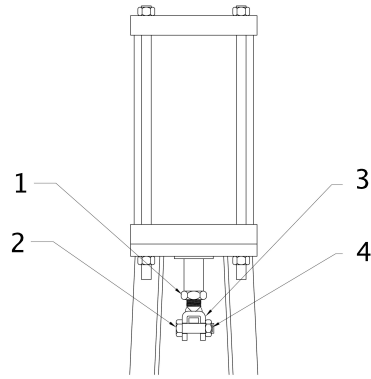

1. Jam nut
2. Gate clamp bolt
3. Gate clamp
4. Gate clamp nut

- b) Remove the gate clamp nuts (4) and bolts (2).
 c) Screw the gate clamp (3) fully into the cylinder rod.
 d) Reattach the gate to the gate clamp and close the valve.
 e) Measure the distance from the tip of the gate to the top of the seal at the bottom of the port.

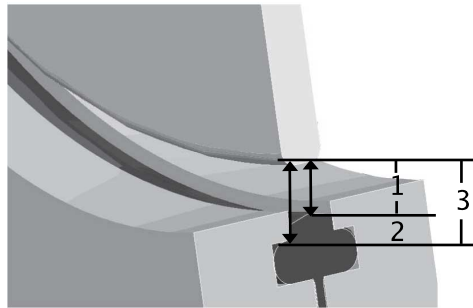

1. Tip of the gate to the top of the seal
2. Adjustment distance
3. Gate clamp adjustment distance

- f) Add this measurement to the adjustment distance for the valve size listed in the table.

Valve size	Adjustment distance
2–4 in. (50–100 DN)	0.06 in. (1.5 mm)
6–24 in. (150–600 DN)	0.13 in. (3.3 mm)

This sum is the gate clamp adjustment distance.

- g) Remove the gate clamp nuts and bolts and raise the cylinder.
 h) Lower the gate clamp by unscrewing the gate clamp from the cylinder rod by the gate clamp adjustment distance calculated above.
 i) Reattach the gate and tighten the gate clamp nuts and bolts.
 j) Tighten the gate clamp jam nut against the cylinder rod.
 k) Close the valve.
 l) Visually inspect the seal.
- If the gate tip is engaged in the seat, then follow the step below.
 - If the gate tip is not engaged in the seat, then repeat the steps above.
4. If the valve has a lockout pin, then follow the steps below:
 a) Close the valve.

b) Check the lockout pin.

If the valve is ...	Then ...
2–4 in. (50–100 DN)	Does the lockout pin pass through the gate clamp?
6 in. (DN 150) and above	Does the lockout pin pass over the top of the gate?

- If yes: Procedure is complete.
- If no: Consult the factory.

Troubleshooting

Knife gate valve operation troubleshooting

Symptom	Cause	Remedy
There is seepage past the packing upon installation.	<ul style="list-style-type: none"> The valve may have been subject to wide temperature variations during shipment. There is normal packing wear. 	Adjust the packing by tightening the packing screws.
The fully-closed valve is leaking past the seat.	The seat or gate is damaged.	Replace the seat or gate with a genuine ITT replacement.
The fully-closed valve is leaking past the seat.	The seal is not compressed correctly.	Set the stroke.
The fully-opened or fully-closed valve is leaking at the joints.	The main seal is damaged .	Replace the main seal.
Excessive force is required to open and close the valve.	The valve is not lubricated properly.	See Lubrication requirements in the Maintenance section.
Excessive force is required to open and close the valve.	There is misalignment between stem and gate.	<ol style="list-style-type: none"> Loosen the actuator and yoke. Check the alignment. Retighten the hardware.
Excessive force is required to open and close the valve.	The packing is too tight.	Consult the factory.

Parts Listings and Cross-Sectionals

Drawing and parts list

Exploded view

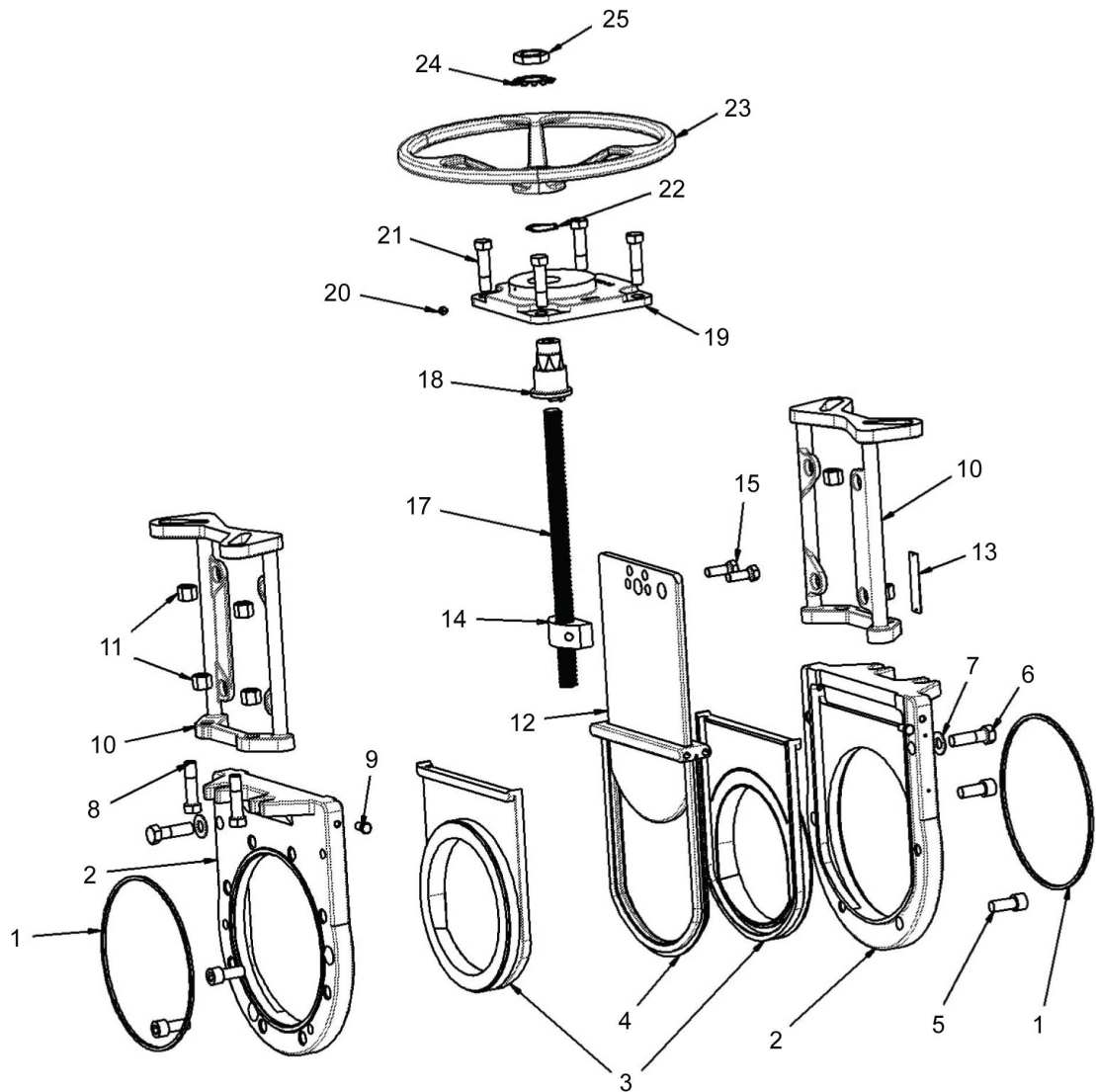

Parts list

Item	Description	Material	
		R' Series	S' Series
1	O-ring	EPDM, viton, aflas	
2	Body	Carbon steel	
3	Liner	Urethane	
4	Main seal (valve seat and chest seal)	EPDM, viton, aflas	
5	Socket head clamping bolt	Stainless steel	
6	Capscrew clamping bolt	Stainless steel	
7	Clamp bolt washer	Stainless steel	

Item	Description	Material	
		R' Series	S' Series
8	Yoke to body bolt	Plated steel	Stainless steel
9	Injection port bolt	Stainless steel	
10	Yoke half	Carbon steel	304 Stainless steel
11	Yoke retainer nut	Carbon steel	Stainless steel
12	Gate	Stainless steel as specified by customer	
13	Identification tag	Stainless steel	
14	Non rising stem nut	Acid resistant bronze	
15	Stem nut bolts	Plated steel	Stainless steel
17	Non rising stem	304 Stainless steel	
18	Drive nut	Bronze	
19	Yoke hub	Carbon steel	Stainless steel
20	Grease fitting	Plated steel	
21	Yoke hub bolts	Plated steel	Stainless steel
22	Wave spring	Stainless steel	
23	Handwheel	Ductile iron	
24	Retainer washer	Stainless steel	
25	Retainer nut	Plated steel	

Visit our website for the latest version of this document and more information:

www.engvalves.com



ENGINEERED FOR LIFE

Engineered Valves
1110 Bankhead Ave
Amory, MS 38821
USA
Tel. (662) 256-7185
Fax (662) 256-7932
E-mail: engvalves.custserv@itt.com