



ITT

Industrial Process

Maintenance Manual

Advantage[®] Actuator 2.0



Engineered for life





Table of Contents

Introduction and Safety	2
Safety message levels.....	2
User health and safety.....	2
Product Description	4
Actuator identification.....	4
Bonnet description.....	5
Valve diaphragm identification.....	6
Maintenance	7
Precautions.....	7
Inspection.....	7
Tighten the bonnet fasteners.....	7
Fastener torque table for valve body to topworks.....	8
Disassemble the valve.....	8
Replace the valve diaphragm.....	9
Adjust the travel (closing) stop.....	12
Replace the spindle o-rings.....	12
Lubrication requirements.....	12
Replace the actuator diaphragm and spring for fail open actuator.....	13
Replace the actuator diaphragm and spring for fail close actuator.....	14
Replace the actuator diaphragm for double acting actuator.....	15
Tighten the actuator cover to cover fasteners.....	15
Fastener torque table for actuator cover to cover.....	15
Parts Listing and Cross-Sectional Drawings	16
Advantage actuator series 3, 5, 8, and 16 parts.....	16
Parts for fixture	17

Introduction and Safety

Safety message levels

Definitions

Safety message level	Indication
 <p>DANGER:</p>	A hazardous situation which, if not avoided, will result in death or serious injury
 <p>WARNING:</p>	A hazardous situation which, if not avoided, could result in death or serious injury
 <p>CAUTION:</p>	A hazardous situation which, if not avoided, could result in minor or moderate injury
 <p>Electrical Hazard:</p>	The possibility of electrical risks if instructions are not followed in a proper manner
NOTICE:	<ul style="list-style-type: none"> • A potential situation which, if not avoided, could result in an undesirable result or state • A practice not related to personal injury

User health and safety

General precautions

This product is designed and manufactured using good workmanship and materials, and meets all applicable industry standards. This product should be used only as recommended by an IIT engineer.



WARNING:

- Misapplication of the valve can result in injury or property damage. Select valves and valve components of the proper materials and make sure that they are consistent with your specific performance requirements. Incorrect application of this product includes but is not limited to:
 - Exceeding the pressure or temperature rating
 - Failing to maintain this product according to the recommendations
 - Using this product to handle caustic or hazardous substances that it is not designed to handle

Qualifications and training

The personnel responsible for the assembly, operation, inspection, and maintenance of the valve must be appropriately qualified. The operating company must do the following tasks:

- Define the responsibilities and competency of all personnel handling this equipment.
- Provide instruction and training.
- Ensure that the contents of the operating instructions have been fully understood by the personnel.

Instruction and training can be carried out by either IIT or the reseller of the valve by order of the operating company.

Non-compliance risks

Failure to comply with all safety precautions can result in the following conditions:

- Death or serious injury due to electrical, mechanical, and chemical influences
- Environmental damage due to the leakage of dangerous materials
- Product damage
- Property damage
- Loss of all claims for damages

Operational safety precautions

Be aware of these safety precautions when operating this product:

- Do not leave hot or cold components of the product unsecured against contact if they are a source of danger.
- Do not remove the contact guard for moving parts when the product is in operation. Never operate the product without the contact guard installed.
- Do not hang items from the product. Any accessories must be firmly or permanently attached.
- Do not use the product as a step or hand hold.
- Do not paint over the identification tag, warnings, notices, or other identification marks associated with the product.

Maintenance safety precautions

Be aware of these safety precautions when performing maintenance on this product:

- You must decontaminate the product if it has been exposed to harmful substances such as caustic chemicals.
- You must immediately fit or reactivate all safety and protective equipment upon completion of work.

Use of unauthorized parts

Reconstruction or modification of the product is only permissible after consultation with IIT. Genuine spare parts and accessories authorized by IIT serve to maintain safety. Use of non-genuine IIT parts can annul liability of the manufacturer for the consequences. IIT parts are not to be used in conjunction with products not supplied by IIT as this improper use can annul all liability for the consequences.

Unacceptable modes of operation

The operational reliability of this product is only guaranteed when it is used as designated. The operating limits given on the identification tag and in the data sheet may not be exceeded under any circumstances. If the identification tag is missing or worn, contact IIT for specific instructions.

Product Description

Actuator identification

Design Overview

The actuator is a spring or double acting pneumatic actuator.

To determine if you have an Advantage actuator or an Advantage actuator 2.0 locate the spindle compressor connection and determine if you have a pin or t-slot connection.



Figure 1: Pin connection for Advantage actuator



Figure 2: T-slot Connection for Advantage actuator 2.0

Model number

The actuator model number is located on the ITT identification tag. The model number is a four digit number defining the actuator as follows.

Table 1: Actuator

Code	Description
B	Advantage actuator 2.0

Table 2: Mode of operation

Code	Description
1	Fail open (spring to open, air to close) (direct acting)
2	Fail close (spring to close, air to open) (reverse acting)
3	Double acting (air to open, air to close)

Table 3: Actuator series

Code ¹	Actuator series ²
03, 04	3
05, 06	5
08, 09	8
15, 16, 17	16

Table 4: Examples

Model number	Description
B308	Advantage actuator 2.0, double acting, series 8
B215	Advantage actuator 2.0, fail close, series 16 with a 15 spring set

¹ For fail close actuators, codes are specific spring combinations.

² Series number equates to diaphragm effective area.

Identification tag

ITT Corporation Pure-Flo®
 S/N XXXXXX-XXX-XXX
 Size - Model #
 Diaphragm Type - xxxx
 Maximum 90PSI (6.2Bar)

Line	Description
1	Valve serial number
2	Valve size and model number
3	Valve diaphragm type
4	Maximum recommended actuation pressure

Bonnet description

Non-Sealed bonnet

The non-sealed bonnet has a weep hole that permits leakage of the process fluid if the diaphragm ruptures.

Sealed bonnet

The sealed bonnet uses a special “V-notch” vent plug, which permits diaphragm inspection.

Figure 3: Weep hole and V-notch vent plug

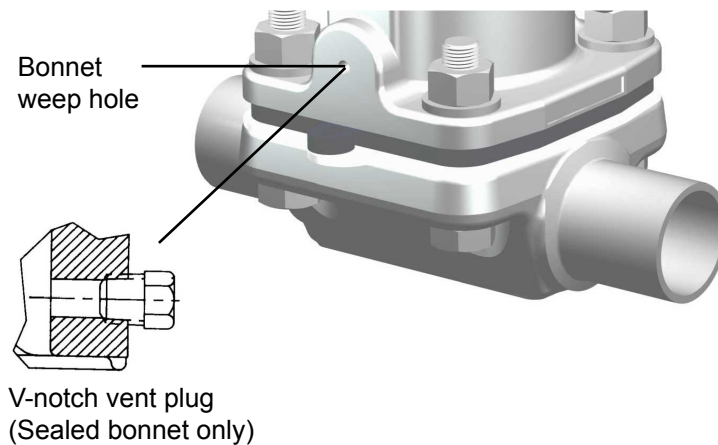

Valve diaphragm identification

Diaphragm tab codes

All diaphragm materials and physical properties are batch traceable via permanent codes molded into the diaphragm tabs. The molding date, grade of diaphragm, and valve size provide traceability to original batch records.



Figure 4: Elastomer diaphragm front



Figure 5: Elastomer diaphragm back

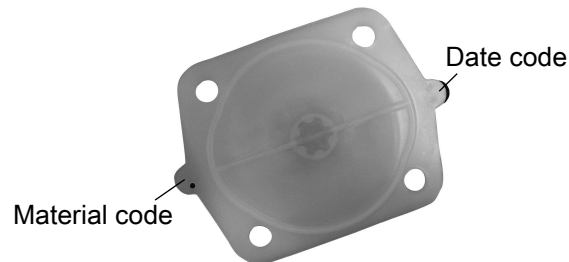

Figure 6: PTFE diaphragm

Maintenance

Precautions

WARNING:

- All procedures must be performed by qualified personnel.
- When the process fluid is hazardous, thermal (hot or cold), or corrosive, take extra precautions. Employ the appropriate safety devices and be prepared to control a process media leak.
- Always wear protective clothing and equipment to safeguard the eyes, face, hands, skin, and lungs from the particular fluid in the line.

CAUTION:

- Disconnect electrical, pneumatic, and hydraulic power before servicing actuator or automation components.

Inspection

Inspection area	What to look for	Action if problem is found
External valve parts	Excessive wear or corrosion	<ul style="list-style-type: none"> • Replace the affected parts • Contact ITT to obtain replacement parts or for specific instructions
Non sealed bonnet	Fluid weeping from the plug	Replace the valve diaphragm
Sealed bonnet	Fluid weeping from the plug Loosen the v-notch vent plug 2-3 turns to check	Replace the valve diaphragm
Actuator's bonnet weep hole and air ports	Air pressure	
Topworks	Spindle binding, excessive noise, or dried lubricant	Lubricate the actuator
Diaphragm and valve body	Leakage between the diaphragm and valve body	Tighten the bonnet fasteners

For more information, see:

- Replace the valve diaphragm in this manual.
- Replace the spindle o-rings in this manual.
- Lubrication requirements in this manual.
- Tighten the bonnet fasteners in this manual.

Tighten the bonnet fasteners

CAUTION:

Do not tighten fasteners while the system is pressurized or at elevated temperatures (greater than 100°F (38°C)).

1. Depressurize the system.
2. Use regulated air pressure to position diaphragm so that valve is slightly open.
You may need to use air pressure to actuate the valve.

3. Tighten the bonnet fasteners in a crisscross pattern.
For more information, see Fastener torque table for valve body to topworks in this manual.
4. Make multiple crisscross passes to build up torque to the final table value. Make additional crisscross passes using final table values to evenly tighten each fastener to within 5% of torque value.
5. Retighten the bonnet fasteners as noted above at ambient conditions after the system has cycled through operating pressure and temperature.
6. Monitor the valve for leakage:

If leakage ...	Then ...
Occurs at the body/bonnet flange sealing area	Depressurize the system and retighten the bonnet fasteners as noted above.
Continues	Depressurize the system and retighten the bonnet fasteners as noted above. (maximum 3rd re-torque)
Continues	Replace the valve diaphragm.

For more information, see Replace the valve diaphragm in this manual.

Fastener torque table for valve body to topworks

Values given are for lubricated fasteners.

Valve size		Bolt size		PTFE diaphragm		Elastomer diaphragm	
Inch	DN	Imperial	Metric	in-lb	N-m	in-lb	N-m
0.50	15	1/4"	M6	25-60	2.8-6.8	20-40	2.3-4.5
0.75	20	1/4"	M6	50-65	5.7-9.1	20-50	2.3-5.7
1.00	25	5/16"	M8	65-90	7.4-11.3	45-70	5.1-7.9
1.50	40	3/8"	M10	200-225	23-25	75-130	8.5-14.7
2.00	50	7/16"	M12	225-275	25-31	100-180	11-20

Guidelines

- Minimum values given will provide a longer diaphragm cycle life for valves in non-autoclave and low thermal cycle conditions.
- Maximum values given may be necessary for autoclave conditions and for high thermal cycle conditions.
- Torques should be applied at near ambient conditions (less than 100°F (38°C)).

Disassemble the valve

1. Remove all line pressure.
2. Do you have a switch package?
 - If yes: Proceed to step 3.
 - If no: Proceed to step 5.
3. Do you have a fail open or double acting actuator?
 - If yes: Proceed to step 4.
 - If no: Proceed to step 5.
4. Do you have a series 33 actuator or adjustable opening stop?
 - If yes: Remove the switch package.
 - If no: Proceed to step 5.
5. If the actuator mode of operation is fail open or fail close, then load the actuator with air.

If the actuator mode of operation is ...	Then ...
Fail open	Load the air port in the upper cover of the actuator with sufficient air to partially close the valve.

If the actuator mode of operation is ...	Then ...
Fail close	Load the air port in the bottom cover of the actuator with sufficient air to partially open the valve.

6. Remove the bonnet fasteners.
7. Lift the topworks assembly from the valve body.
8. If the actuator mode of operation is fail open, then remove pressure load from the actuator.
9. Do you have a fail open or double acting actuator?
 - If yes: Proceed to step 10.
 - If no: Procedure is complete.
10. Do you have a series 33 actuator or adjustable opening stop?
 - If yes: When the actuator is not on the valve body, do not allow the flats on the indicating spindle to move below the upper cover spindle o-ring.
 - If no: Procedure is complete.

Replace the valve diaphragm

1. Disassemble the valve.
For more information, see Disassemble the valve in this manual.
2. If the actuator mode of operation is fail open, pressurize the actuator by applying air to the upper cover, slightly extending the compressor and diaphragm.
3. Unscrew the diaphragm from the compressor by turning the diaphragm counterclockwise.
The replacement diaphragm should be identical in size and grade to the original diaphragm.
4. Insert the tube nut by sliding the flat end into the actuator spindle so that it rests flush in the slot.
5. Put the compressor over top of the tube nut.
6. If replacing a PTFE diaphragm, follow these steps.
 - a) Install the new elastomer backing cushion over the tube nut.



- b) Invert the PTFE diaphragm by pressing the center of the diaphragm face with your thumbs while holding the edge of the diaphragm with your fingers.

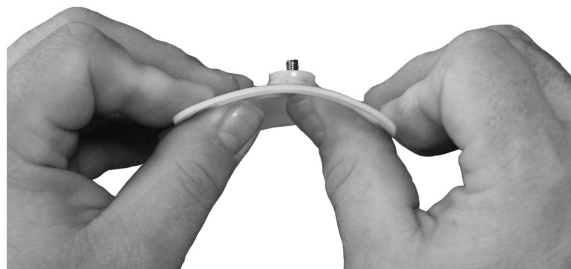

- c) Engage the threads of the diaphragm into the tube nut by rotating clockwise.



- d) Continue rotating the PTFE diaphragm clockwise into the compressor while securing the backing cushion from rotating.



7. Rotate the diaphragm until hard stop or heavy resistance is achieved and additional force does not significantly rotate the diaphragm into the compressor.

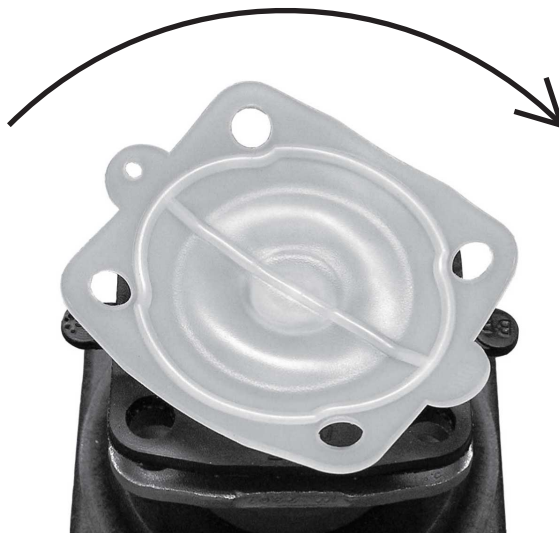

8. If replacing a PTFE diaphragm, re-invert the diaphragm.



9. Back off (no more than half turn) until the bolt holes in diaphragm and the bonnet flange align.



10. If the actuator mode of operation is fail open or fail close, select one of these steps.

If the actuator mode of operation is ...	Then ...
Fail open	Reduce the air pressure until the back of the diaphragm is flat against the bonnet.
Fail close	<ol style="list-style-type: none"> 1. Connect the air line to the lower air cover. 2. Load the chamber with sufficient air to move the diaphragm upward until the back of diaphragm is flat against the bonnet. Do not apply excessive air pressure that results in inversion of the diaphragm.

11. Replace the topworks assembly on the body and tighten the bonnet fasteners.
For more information, see Tighten the bonnet fasteners in this manual.
12. If the actuator mode of operation is fail open or double acting, examine the actuator upper cover for leakage past the indicating spindle o-ring seal. If leakage is present, replace the spindle o-rings.
13. If the actuator mode of operation is fail open, release the air, allowing the valve to open.
14. If there is a travel (closing) stop, reset it to ensure proper closure.
For more information, see Adjust the travel (closing) stop in this manual.

Adjust the travel (closing) stop

The travel stop is designed to prevent overloading of the diaphragm, thus prolonging diaphragm life. Travel stops are factory set and do not require routine adjustment. However, travel stop adjustment is recommended when replacing a valve diaphragm.

A travel stop is optional on series 3, 5, 8, and 16 actuators.

1. Release the air pressure in the actuator covers.
2. Remove the clear plastic cap or switch package, if equipped.
3. Loosen the jam nuts and back off one turn.
4. If the actuator is a double acting or fail open actuator, then apply enough pressure in the upper cover to close the valve.
5. For all modes of operation, turn the lower nut clockwise while preventing the adjusting bushing from rotating until the valve begins to leak.
6. Turn the lower nut counterclockwise while continuing to prevent the adjusting bushing from rotating until the valve stops leaking.
7. Tighten the jam nuts together.
8. Replace the clear plastic cap or switch package, if equipped.

Replace the spindle o-rings

1. Disconnect the air lines.
2. Remove any control packages.
3. Disassemble the valve.

For more information, see Disassemble the valve in this manual.

4. Disassemble the actuator.

For more information, see Replace the actuator diaphragm and spring for proper mode of operation (fail open, fail close, or double acting) in this manual.

5. Withdraw the valve diaphragm, compressor, and spindle assembly from the bonnet.
6. Replace the o-rings and lubricate the new o-rings.

For more information, see Lubrication requirements in this manual.

7. Replace the valve diaphragm, compressor, and spindle assembly on the bonnet.
8. Reassemble the actuator.

For more information, see Replace the actuator diaphragm and spring for proper mode of operation (fail open, fail close, or double acting) in this manual.

9. Reassemble the valve.

For more information, see Replace the actuator diaphragm and spring for proper mode of operation (fail open, fail close, or double acting) in this manual.

10. Reconnect the air lines.
11. If the actuator mode of operation is fail open or double acting, then follow the steps below:
 - a) Examine the actuator upper cover for leakage past the indicating spindle o-ring seal.
 - b) If leakage is present, then replace the spindle o-rings.

Lubrication requirements



WARNING:

Standard lubricants are as outlined below. Special lubricants may be required for oxygen or other unique services. Contact IIT for evaluation of non-standard lubricants.

Lubrication schedule

Remove residual grease prior to re-lubrication. Lubricate the spindle, o-rings, and mating surfaces whenever the topworks is disassembled.

Acceptable lubricants

Brand	Lubricant type
Chevron	FM ALC EP 2 (FDA Compliant)

Replace the actuator diaphragm and spring for fail open actuator

One fixture exists for the series 3, 5, and 8 actuators and one for the series 16 actuator.



CAUTION:

Actuator plates are under load. Series 3, 5, 8, and 16 fail open actuators contain powerful springs and should not be disassembled unless properly fixtured.

1. If present, remove the switch package.
2. Disconnect the air lines.
3. ITT recommends that the following steps be performed on a bench with the body removed from the actuator:
 - a) Disassemble the valve.
For more information, see Disassemble the valve in this manual.
 - b) Unscrew the diaphragm from the compressor by turning it counterclockwise.
4. Remove the actuator fasteners and lift off the top cover.
5. Disassemble the actuator with a fixture:
 - a) Place the actuator in a fixture.
 - b) Loosen the indicator spindle two turns.
 - c) Place the actuator centrally in the fixture, locating the compressor over the correct spacer, dependent on valve size, in the fixture lower plate.
 - d) Place the support plate and spacer plate on the actuator top plate.
 - e) Turn the fixture handwheel clockwise to remove the load from the indicator spindle.
 - f) Remove the spindle and turn the fixture handwheel counterclockwise until the spring load is relieved.
Use care, as the spindle thread may pinch the actuator diaphragm and restrict spring extension.
6. Replace the actuator diaphragm and spring:
 - a) Place the spring in the lower cover and set an actuator plate, concave side down, over the valve spindle.
 - b) Position the actuator in the fixture over the spacer.
 - c) Place the support plate on the actuator plate.
 - d) Set the spacer plate on top.
 - e) Turn the fixture handwheel clockwise and compress the spring until the actuator plate shoulders on the spindle.
Use care to ensure the spindle goes through the actuator plate center hole.
 - f) Slide the actuator diaphragm over the valve spindle using care to ensure the top hat is in the upper cover.
 - g) Position the actuator diaphragm so the bolt clearance holes line up with threaded inserts in lower cover.
7. Reassemble the actuator with a fixture:
 - a) Place an actuator plate, concave side up, over the valve spindle.
 - b) Prepare spindle nut surface with Loctite 7649 Primer N.
 - c) Apply Blue Loctite #242 and thread the indicating spindle on the valve spindle by hand.

- d) Turn the fixture handwheel counterclockwise to remove the load and remove the actuator from the fixture.
- e) Clamp the slotted plate in a vise and pull so the actuator slips free.
- f) Tighten the indicator spindle with a wrench using care to ensure the actuator diaphragm remains properly aligned.
- g) Position the upper actuator cover so the 1/8" NPT inlets in the upper and lower covers are in line.
- h) Tighten the actuator cover to cover fasteners.

For more information, see Tighten the actuator cover to cover fasteners in this manual.

Replace the actuator diaphragm and spring for fail close actuator

One fixture exists for the series 3, 5, and 8 actuators and one for the series 16 actuator.

1. If present, remove the switch package.
2. Disconnect the air lines.
3. ITT recommends that the following steps be performed on a bench, with the body removed from the actuator:
 - a) Disassemble the valve.
For more information, see Disassemble the valve in this manual.
 - b) Unscrew the diaphragm from the compressor by turning it counterclockwise.
4. Apply air to the lower cover to simplify disassembly from the body, then release the air.
5. Remove the valve diaphragm and plastic indicator spindle plug (found on the spindles) by turning them counterclockwise.
6. Disassemble the actuator with a fixture:
 - a) Position the actuator centrally in a fixture, locating the compressor over the correct spacer in the fixture lower plate.
 - b) Drop the stem guide through the center of the fixture handwheel and position it in the actuator indicator spindle #10-24 UNC tapped hole (former plug location).
 - c) Turn the fixture handwheel clockwise until the stem rests on the actuator top cover.
 - d) Remove all the cover to cover caps, fasteners, and washers.
 - e) Turn the fixture handwheel counterclockwise until the spring load is relieved.
 - f) Remove the actuator upper cover, lift out spring(s), and unthread the indicator spindle.
 - g) Remove the top actuator plate and actuator diaphragm.
7. Replace the actuator diaphragm and spring:
 - a) Install the new actuator diaphragm (top hat up).
Be sure the diaphragm is positioned so the diaphragm bolt holes line up with the actuator cover bolt holes with no stretching of the diaphragm.
 - b) If the spring needs to be replaced, then install a new spring.
 - c) If the spring does not need to be replaced, then install an old spring.
8. Reassemble the actuator with a fixture:
 - a) Place the correct spacer, dependent on valve size, over the pin in the fixture lower plate.
 - b) Position the actuator sub-assembly, including spring(s) and upper cover, over the spacer (the compressor rests on the spacer).
 - c) Drop the stem guide through center of the fixture handwheel, actuator upper cover, and locate it in the actuator indicator.
 - d) Position the actuator upper cover so the 1/8" NPT inlets in the upper and lower covers are in line and the rod guides slide through the clearance holes.
 - e) Turn the handwheel clockwise to compress the spring(s) until the covers almost touch.
 - f) Remove the four threaded rod guides.
 - g) Start tightening the actuator cover fasteners and continue to compress the spring(s) until the covers touch.
 - h) Place the remaining washers and fasteners in the top cover.
 - i) Tighten the actuator cover to cover fasteners.

For more information, see Tighten the actuator cover to cover fasteners in this manual.

Replace the actuator diaphragm for double acting actuator

1. If present, remove the switch package
2. Disconnect the air lines.
3. IIT recommends that the following steps be performed on a bench with the body removed from the actuator:
 - a) Disassemble the valve.
For more information, see Disassemble the valve in this manual.
4. Remove the actuator fasteners and lift off the upper cover.
5. Remove the actuator top plate and actuator diaphragm.
6. Remove the indicating spindle
7. Install the new actuator diaphragm (top hat up).
Be sure the actuator diaphragm is positioned so the diaphragm bolt holes line up with the cover bolt holes with no stretching of the diaphragm.
8. Replace the actuator top plate and actuator diaphragm:
 - a) Prepare the spindle nut surface with Loctite 7649 Primer N.
 - b) Apply Blue Loctite #242 to the indicating spindle.
 - c) Replace the indicating spindle.
9. Assemble the upper cover using care to keep the air fitting in line with the lower cover air fitting.
10. Tighten the actuator cover to cover fasteners.

For more information, see Tighten the actuator cover to cover fasteners in this manual.

Tighten the actuator cover to cover fasteners

Tighten the bonnet fasteners in a crisscross pattern with proper torque.

1. Tighten the bonnet fasteners in a crisscross pattern in accordance with Fastener torque table for actuator cover to cover.
2. Make multiple crisscross passes to build up torque to final table values.

Fastener torque table for actuator cover to cover

Actuator series	Bolt size	Torque	
		Imperial	N-m
Series 3, 5, 8	#10	20	2.3
Series 16	1/4"	35	4.0

Values given are for lubricated fasteners.

Torques should be applied at near ambient conditions (less than 100°F (38°C)).

Parts Listing and Cross-Sectional Drawings

Advantage actuator series 3, 5, 8, and 16 parts

List of parts

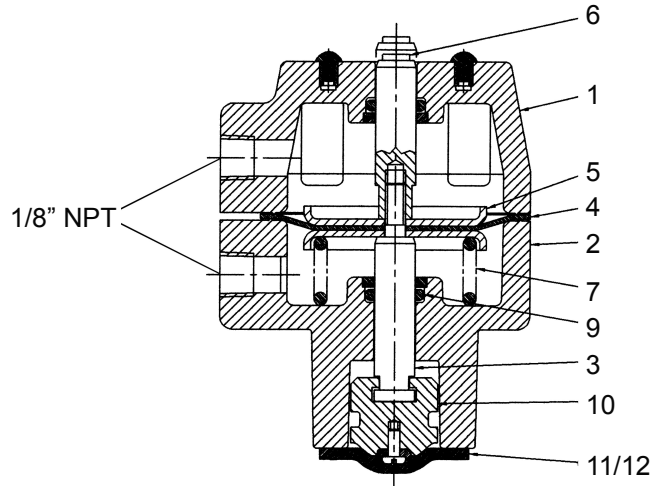

Figure 7: Fail open and double acting actuator

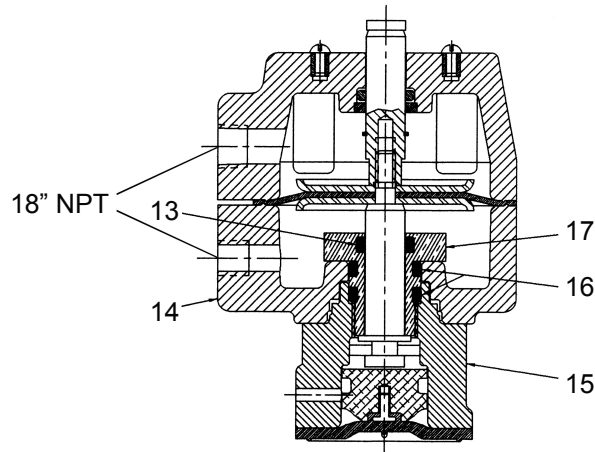

Figure 8: Low profile actuator

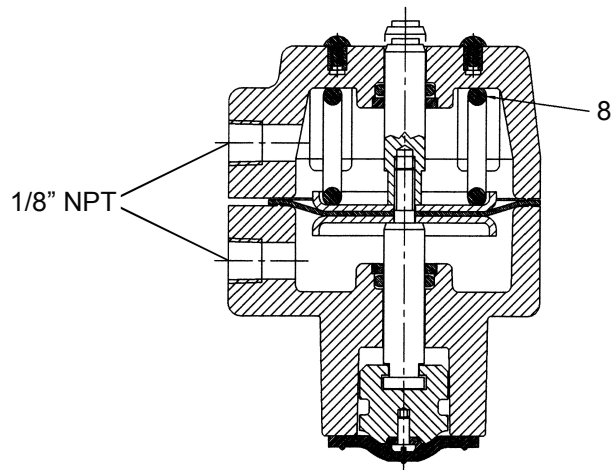

Figure 9: Fail close actuator

Item	Description	Material	Quantity
1	Upper Actuator Cover	Plastic	1
2	Lower Actuator Cover	Plastic	1
3	Valve Spindle	Stainless Steel	1
4 ³	Diaphragm, Actuator	Buna-N	1
5	Plate, Actuator	Stainless Steel or Carbon Steel Nickel Plated	2
6	Spindle, Indicating	Stainless Steel	1
7 ⁴	Spring	Steel	1
8	Spring	Steel	1
9 ³	O-Ring	FKM	2
10	Compressor	Stainless Steel, Cast Iron, Zinc or Bronze	1
11 ³	Diaphragm	As required	1
12 ³	Backing Cushion	EPDM	1
13 ³	O-Ring	FKM	1
14	Lower Actuator Cover	Plastic	1
15	Bonnet	Stainless Steel	1
16 ³	O-Ring	FKM	2
17	Bushing	Brass	1

Parts for fixture

List of parts

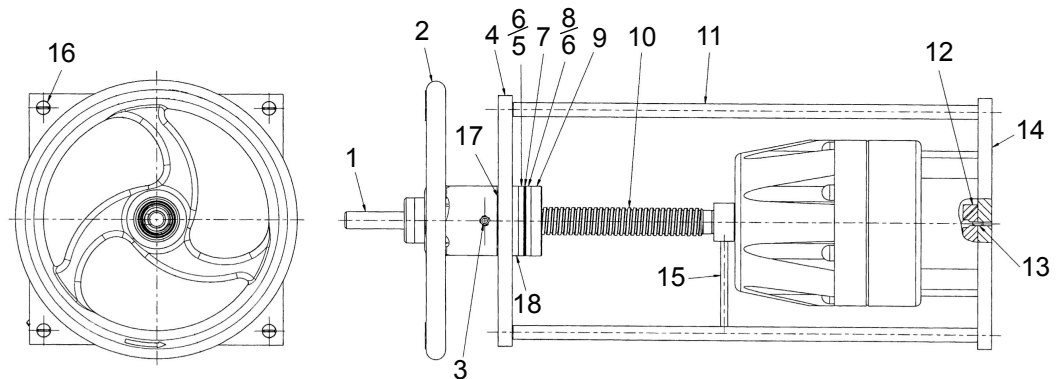

Figure 10: Fixture drawing

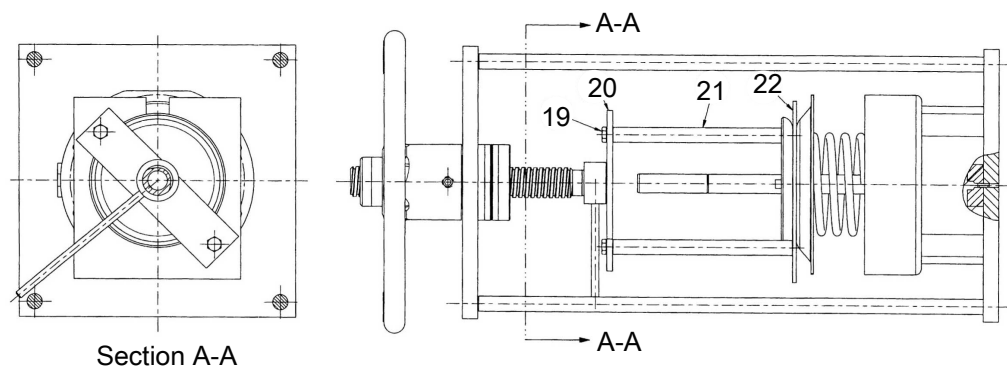

Figure 11: Fixture drawing for fail open actuators

³ Recommended spare parts

⁴ Only for fail open actuators

Item	Description	Quantity
1 ⁵	Centering Rod	1
2	Handwheel	1
3	Set Screw	2
4	Upper Plate	1
5	Thrust Washer	2
6	Thrust Race	2
7	Thrust Bearing	1
8	Thrust Race	1
9	Bushing	1
10	Stem	1
11	Outer Column	4
12 ⁶	Spacer	1
13	Spring Pin	1
14	Lower Plate	1
15	Rod	1
16	Machine Screw	4
17	Shim Washer	As required
18	Spacer Plate	1
19 ⁷	Cap Screw	2
20 ⁷	Bar	1
21 ⁷	Inner Column	2
22 ⁷	Support Plate	1

⁵ Not used with Fail open actuators

⁶ One spacer for each size

⁷ Only for Fail open actuators



ITT

Visit our Web site for the latest version of this document and more information
www.ittpureflo.com

Pure-Flo
33 Centerville Road
Lancaster, PA 17603
USA
Tel. (717) 509-2200
Fax (717) 509-2316
E-mail: pureflo.custserv@itt.com

Richards Street, Kirkham
Lancashire PR4 2HU
England
Tel. +44-1772-682696
Fax +44-1772-686006