



ITT

Industrial Process

Installation, Operation, and Maintenance Manual

Cam-Tite Ball Valve



Engineered for life





Table of Contents

Introduction and Safety	2
Safety message levels.....	2
User health and safety.....	2
Transportation and Storage	4
Handling and unpacking guidelines.....	4
Storage, disposal, and return requirements.....	4
Product Description	5
General description.....	5
Installation	6
Install the ball valve.....	6
Tighten the stem seal nut.....	7
Tighten the cover bolts.....	7
Adding a third party feedback device.....	8
Maintenance	11
Precautions.....	11
Inspection.....	11
Replace the cover gasket.....	11
Replace the stem seal.....	11
Replace the seat.....	13
Troubleshooting	14
Ball valve operation troubleshooting.....	14
Parts Listings and Cross-Sectional Drawings	15
Drawing and parts list.....	15

Introduction and Safety

Safety message levels

Definitions

Safety message level	Indication
 <p>DANGER:</p>	A hazardous situation which, if not avoided, will result in death or serious injury
 <p>WARNING:</p>	A hazardous situation which, if not avoided, could result in death or serious injury
 <p>CAUTION:</p>	A hazardous situation which, if not avoided, could result in minor or moderate injury
 <p>Electrical Hazard:</p>	The possibility of electrical risks if instructions are not followed in a proper manner
NOTICE:	<ul style="list-style-type: none"> • A potential situation which, if not avoided, could result in an undesirable result or state • A practice not related to personal injury

User health and safety

General precautions

This product is designed and manufactured using good workmanship and materials, and meets all applicable industry standards. This product should be used only as recommended by an IIT engineer.



WARNING:

- Misapplication of the valve can result in injury or property damage. Select valves and valve components of the proper materials and make sure that they are consistent with your specific performance requirements. Incorrect application of this product includes but is not limited to:
 - Exceeding the pressure or temperature rating
 - Failing to maintain this product according to the recommendations
 - Using this product to contain or control media that is incompatible with the materials of construction

Qualifications and training

The personnel responsible for the assembly, operation, inspection, and maintenance of the valve must be appropriately qualified. The operating company must do the following tasks:

- Define the responsibilities and competency of all personnel handling this equipment.
- Provide instruction and training.
- Ensure that the contents of the operating instructions have been fully understood by the personnel.

Instruction and training can be carried out by either IIT or the reseller of the valve by order of the operating company.

Non-compliance risks

Failure to comply with all safety precautions can result in the following conditions:

- Death or serious injury due to electrical, mechanical, and chemical influences
- Environmental damage due to the leakage of dangerous materials
- Product damage
- Property damage
- Loss of all claims for damages

Operational safety precautions

Be aware of these safety precautions when operating this product:

- Do not leave hot or cold components of the product unsecured against contact if they are a source of danger.
- Do not remove the contact guard for moving parts when the product is in operation. Never operate the product without the contact guard installed.
- Do not hang items from the product. Any accessories must be firmly or permanently attached.
- Do not use the product as a step or hand hold.
- Do not paint over the identification tag, warnings, notices, or other identification marks associated with the product.

Maintenance safety precautions

Be aware of these safety precautions when performing maintenance on this product:

- You must decontaminate the product if it has been exposed to harmful substances such as caustic chemicals.
- You must immediately fit or reactivate all safety and protective equipment upon completion of work.

Use of unauthorized parts

Reconstruction or modification of the product is only permissible after consultation with IIT. Genuine spare parts and accessories authorized by IIT serve to maintain safety. Use of non-genuine IIT parts can annul liability of the manufacturer for the consequences. IIT parts are not to be used in conjunction with products not supplied by IIT as this improper use can annul all liability for the consequences.

Unacceptable modes of operation

The operational reliability of this product is only guaranteed when it is used as designated. The operating limits given on the identification tag and in the data sheet may not be exceeded under any circumstances. If the identification tag is missing or worn, contact IIT for specific instructions.

Transportation and Storage

Handling and unpacking guidelines



CAUTION:

Always observe the applicable standards and regulations regarding the prevention of accidents when handling the product.

Handling guidelines

Follow these guidelines when handling the product to prevent damage:

- Use care when handling the product.
- Leave protective caps and covers on the product until installation.

Unpacking guidelines

Follow these guidelines when unpacking the product:

1. Inspect the package for damaged or missing items upon delivery.
2. Note any damaged or missing items on the receipt and freight bill.
3. If anything is out of order, file a claim with the shipping company.

Storage, disposal, and return requirements

Storage

If you are not immediately installing the product after delivery, store it as follows:

- Store the product in a dry room that maintains a constant temperature.
- Make sure that the products are not stacked on top of one another.

Disposal

Dispose of this product and associated components in compliance with federal, state, and local regulations.

Return

Ensure these requirements are met before you return a product to ITT:

- Contact ITT for specific instructions on how to return the product.
- Clean the valve of all hazardous material.
- Complete a Material Safety Data Sheet or Process Data Sheet for any process fluid that could remain on the valve.
- Obtain a Return Material Authorization from the factory.

Product Description

General description

Design overview

The Cam-Tite Ball Valve has developed a reputation for performance unequaled by conventional floating ball designs. The difference is in the ball, where around the port edge the spherical surface is cut away, forming a bevel that passes completely around the port opening. This is one of the most important design features of the Cam-Tite Ball Valve since it is the difference in the effective distance across the beveled surfaces and the distance across the spherical surface that actually energizes the seat when the valve is closed.

Features

- Minimizes pressure on seats to reduce cold flow and extend seat life.
- Eliminates the problem of “breakaway torque” in valves that must rest in the open position for long periods.
- Assures positive sealing regardless of line pressure or pressure differential.
- Eliminates seat damage caused by the leading edge of the ball port cutting into the seat as the ball closes.
- When valve is furnished with a means for relieving body cavity pressure (i.e. a cavity vent), an arrow on the exterior of the valve indicates the direction of pressure tightness.

Valve identification

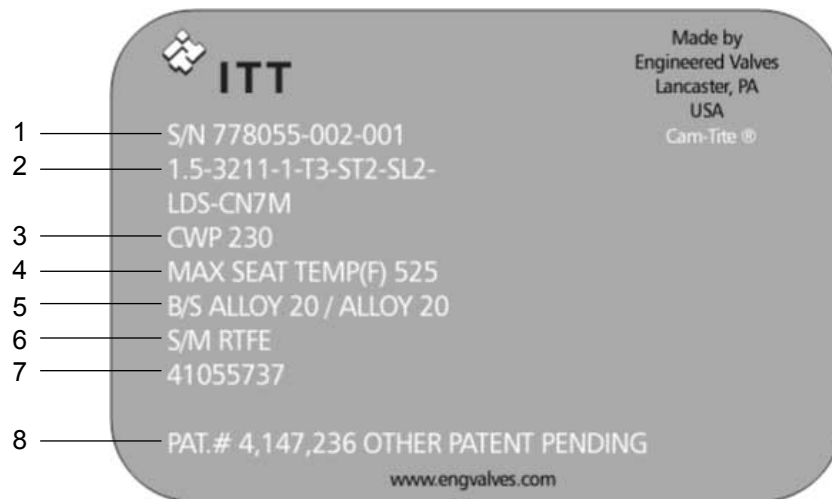

Item	Description
1	Serial number
2	Figure number
3	Cold working pressure
4	Maximum seat temperature
5	Ball/stem material
6	Seat material
7	Customer requested tag number
8	Patent number

Installation

Install the ball valve

- This valve can be installed in any position consistent with good piping practices.
 - If this valve has been furnished with a means for relieving body cavity pressure (i.e. a cavity vent), an arrow on the exterior of the valve indicates the direction of pressure tightness.
1. If this valve is weld end, it may be welded into the pipeline without disassembly.

Utilize welding procedures in accordance with Section IX of the ASME Boiler and Pressure Vessel Code.

- a) Put the valve in the “open” position during welding and keep it open until it cools to ambient temperature.
- b) In addition, a 350°F Tempilstik (for PTFE, RTFE, and PEEK seats and seals) or a 200°F Tempilstik (for UHMWP seats and seals) must be used to monitor the temperature of the seat/gasket area. The figure below shows the location on the valve body where the Tempilstik marks should be placed. This is the area in line with the body/cover flange.

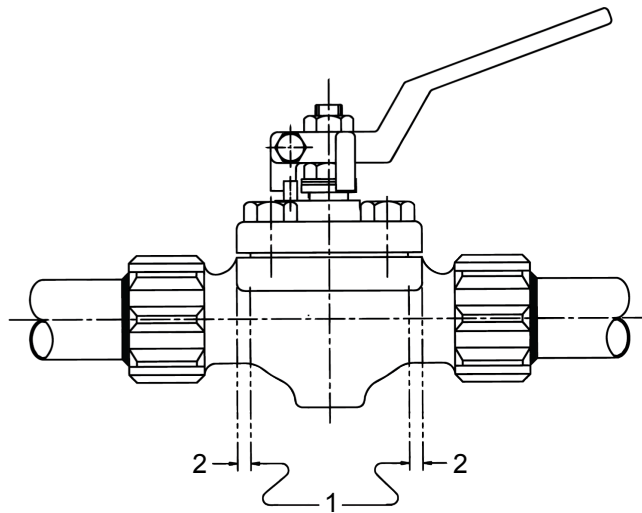

Item	Description
1	Temperature monitoring areas
2	0.25 in. approximately

- c) Welding should be controlled to maintain this area below 350°F or 200°F as noted above.
 - d) If valves are furnished with other than PTFE, RTFE, PEEK, or UHMWP seats or seals, then contact the factory for recommended welding procedures.
2. Tighten the stem seal nut.
For more information see [Tighten the stem seal nut](#) (page 7).
 3. Install the operating handle on the valve stem with the handle sitting flush on top of the stem seal nut.
For sizes 0.5–2 in. (15–50 DN) the handle posts must be aligned with the groove pin travel stop to assure proper rotation of the handle.

If the valve size is ...	Then ...
0.5–2 in. (15–50 DN)	Tighten the hex jam nut and handle screw
3–6 in. (80–150 DN)	Tighten handle screw

4. Tighten the cover bolts.
For more information see [Tighten the cover bolts](#) (page 7).
5. If necessary, repeat steps 2 through 4 above approximately 24 hours after system reaches operating temperature and pressure.

Tighten the stem seal nut

1. Hand tighten the stem seal nut to take up the pre-travel.
2. If the stem seal is PTFE, RTFE, or UHMWP, then tighten the stem seal nut in a clockwise direction in accordance with the stem seal nut torque.

NOTICE:

Do not back off stem seal nut while the valve is under pressure or in the closed position.

Table 1: Stem seal nut torque for PTFE, RTFE, and UHMWP stem seals

Valve size (in.)	Valve size (DN)	Torque (ft-lbs.)
0.5–1	15–25	9
1.5	40	10
2	50	16
3	80	40
4	100	40
6	150	105

3. If the stem seal is graphite, then tighten the stem seal nut until the belleville spring washers are flat.

Tighten the cover bolts



CAUTION:

Do not loosen the cover bolts while the valve is pressurized.

1. Apply a lubricant with a coefficient of friction between 0.05 and 0.06 on the threads and under the head of the bolt.

2. Evenly tighten all cover bolts using the criss-cross method in accordance with the torques below.

Table 2: Torque by pressure class (ft-lbs) for all gaskets except graphite

Valve size (in.)	Valve size (DN)	Pressure class	Bolt Torque			
			Pass 1	Pass 2	Pass 3	Pass 4
0.5–1	15–25	150, 300	5	10	10	N/A
0.5–1	15–25	600	5	10	20	20
1.5	40	150, 300	5	15	15	N/A
1.5	40	600	5	10	30	30
2	50	150, 300	5	10	25	25
2	50	600	10	25	50	50
3	80	150, 300	5	10	25	25
3	80	600	10	25	50	50
4	100	150, 300	5	10	33	33
4	100	600	10	30	78	78
6	150	150	10	25	50	50
6	150	300	10	30	75	75

Table 3: Torque by pressure class (ft-lbs) for graphite gasket material

Valve size (in.)	Valve size (DN)	Pressure class	Bolt torque			
			Pass 1	Pass 2	Pass 3	Pass 4
0.5–1	15–25	150, 300, 600	5	10	29	29
1.5	40	150, 300, 600	5	10	29	29
2	50	150, 300, 600	10	25	55	55
3	80	150, 300, 600	10	25	58	58
4	100	150, 300, 600	10	30	60	60
6	150	150	20	50	145	145
6	150	300	20	50	200	200

Adding a third party feedback device



CAUTION:

ITT advises that our factory assemble and mount all third party feedback devices to ensure the safe and correct operation of the valves.

NOTICE:

- ITT recommends the use of a double nut when installing automation on bare valve stems.
- To prevent possible damage to the valve stem, do not use the travel stop in conjunction with an actuator.
- ITT is not responsible for failure of the valve caused by misapplication or faulty mounting of any third party accessory not install at ITT's factory.
- Do not back off stem seal nut while the valve is under pressure or in the closed position.

Refer to the section on operating torques and max stem torques found in the ITT Cam-Tite catalog for proper sizing of any actuator.

1. If the valve size is 0.5–2 in. (15–50 DN), then:
 - a) Remove the upper stem nut.
 - b) Remove the handle.

- c) Reattach the upper stem nut to the stem to create a “double-nutting” situation. This can be done following one of these options:

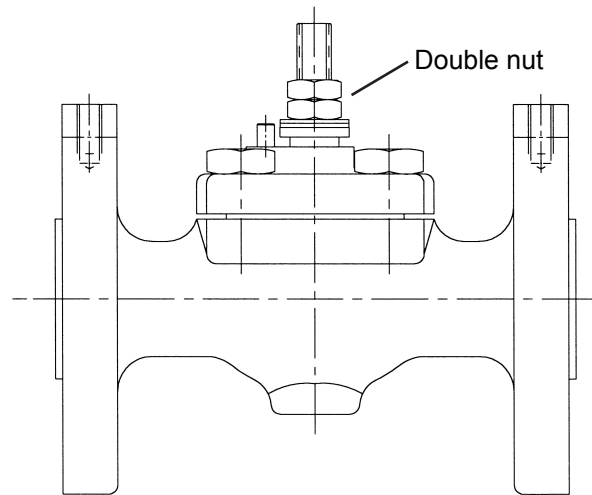

Figure 1: Double nut

- Thread the upper stem nut back on the stem and jam it against the stem seal nut.
- Slide a nut clip over the stem, thread upper stem nut back on the stem, and fold the nut clip arms against the flats of the upper and lower stem nuts (two arms against each nut).

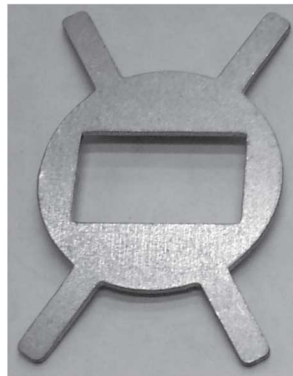

Figure 2: Nut clip

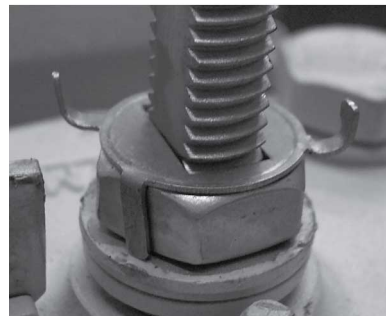

Figure 3: Installed nut clip

This will prevent the stem seal nut from vibrating loose and allowing leakage past the stem.

2. If the valve size is 3–6 in. (80–150 DN), then:
 - a) Remove the handle and replace the standard stem seal nut with a modified stem seal nut.

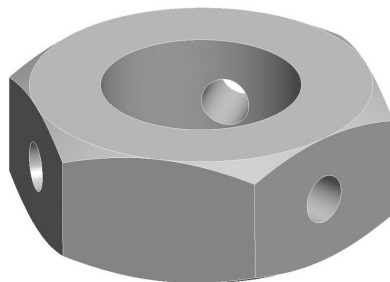

Figure 4: Modified stem seal nut

- b) Tighten the stem seal nut.
For more information, see [Tighten the stem seal nut](#) (page 7).
- c) Tighten the set screw.
- d) Remove the valve's rotational stop pin.

3. Set the actuator's travel stops to ensure proper open and closed positioning of the valve.

Maintenance

Precautions



WARNING:

- All procedures must be performed by qualified personnel.
- When the process fluid is hazardous, thermal (hot or cold), or corrosive, take extra precautions. Employ the appropriate safety devices and be prepared to control a process media leak.
- Always wear protective clothing and equipment to safeguard the eyes, face, hands, skin, and lungs from the particular fluid in the line.

Inspection

Inspection area	What to look for	Action if problem is found
External valve parts	Excessive wear or corrosion	<ul style="list-style-type: none"> • Replace the affected parts • Contact ITT to obtain replacement parts or for specific instructions
Ball valve	Leakage or high operating torque	Disassemble the valve, inspect components, and replace the damaged parts

Replace the cover gasket

1. Relieve pressure from the valve and place the valve in the open position.
2. Remove the cover bolts and lift the cover assembly off the valve body.
3. Remove the cover gasket from the valve body recess or from the cover.
4. Inspect the sealing surfaces of the valve body and cover. If any components are damaged, then replace the components.
5. Replace the cover gasket and install the cover assembly onto the valve body.

NOTICE:

Be sure the ground spring is in place over the flat of the stem and stem shoulder. The spring should bear against the bottom of the cover and top of the ball. Be sure the stem is inserted into the ball and the cover gasket is properly in place. To avoid damage to the gasket, place the gasket on the cover and install the cover (with gasket) onto the body.

6. Install and tighten the cover bolts.
For more information see [Tighten the cover bolts](#) (page 7).

Replace the stem seal

1. Relieve pressure from the valve and place the valve in the open position.
2. Remove the cover bolts and lift the cover assembly off the valve body.
3. Remove the following parts:

1. Hex jam nut on top of handle (1/2-2 in. sizes)
2. Handle
3. Stem seal nut
4. Spring washers
5. Flat washer (1/2-2 in. sizes) or rotational stop (3-6 in. sizes)
6. Gland ring
7. Grounding spring on stem
4. Remove the stem from the cover and remove the upper and lower stem seals from cover counterbore.
5. Inspect and clean the stem and the counterbore of the cover. If any components are damaged, then replace the components.
6. Replace the stem seals:

If the valve is ...	Then ...
Non-Firesafe	<ol style="list-style-type: none"> 1. If lubricant is permitted, apply a light film of DuPont Krytox GPL 206 or other compatible lubricant to stem and stem seal. 2. Install the stem seal over the threaded end of the stem and position it on the stem shoulder. 3. Insert the stem through the cover from the bottom side.
Firesafe	<ol style="list-style-type: none"> 1. Install the lower bearing over the threaded end of the stem and position it on the stem shoulder. 2. Install the graphite stem seal over the threaded end of the stem and position it on the lower bearing. 3. Insert the stem through the cover from the bottom side.

7. Install the following parts over the threaded stem in the order listed:
 1. Stem seal. If lubricant is permitted, apply a light film of DuPont Krytox GPL 206 or other compatible lubricant to second stem seal.
 2. Upper bearing (Firesafe valve only)
 3. Gland ring
 4. Flat washer (1/2-2 in. sizes) or rotational stop (3-6 in. sizes)
 5. Spring washers
 6. Stem seal nut
8. Tighten the stem seal nut.
For more information see [Tighten the stem seal nut](#) (page 7).
9. Install the handle:

If the valve size is ...	Then ...
0.5–2 in. (15–50 DN)	Install the handle and tighten the hex jam nut and handle screw
3–6 in. (80–150 DN)	Install the handle and tighten the handle screw

10. Clean and inspect the cover gasket recess in the valve body and cover.
11. Inspect the cover gasket. If it is damaged, then replace the cover gasket.
For more information see [Replace the cover gasket](#) (page 11).
12. Install the cover assembly onto the valve body.

NOTICE:

Be sure the ground spring is in place over the flat of the stem and stem shoulder. The spring should bear against the bottom of the cover and top of the ball. Be sure the stem is inserted into the ball and the cover gasket is properly in place. To avoid damage to the gasket, place the gasket on the cover and install the cover (with gasket) onto the body.

13. Install and tighten the cover bolts.
For more information see [Tighten the cover bolts](#) (page 7).
14. Cycle the valve several times.
15. If the valve has been removed from the pipeline for maintenance, then reinstall the valve.
For more information see [Install the ball valve](#) (page 6).

Replace the seat

1. Relieve pressure from the valve and place the valve in the open position.
 2. Remove the cover bolts and lift the cover assembly off the valve body.
 3. Lift the ball and seats out of the body with a screwdriver or similar tool. If the ball and seats do not slide easily out of the valve, then check to make sure the ball is in the open position. The stem engagement should be perpendicular to the pipeline.
-

NOTICE:

Be sure to not damage the surface of the ball.

4. Inspect and clean the ball and the body sealing surfaces. If any components are badly scratched or gouged, then replace the components.
 5. Apply a light film of lubricant to the ball and both sides of each of the seat assemblies.
Use DuPont Krytox GPL 206 or other compatible lubricant.
 6. Hold the ball and seats so the I.D.'s of the seats are aligned with the I.D. of the ball port.
 7. Simultaneously slide the two seat assemblies and the ball into the valve body. If the ball and seats do not slide easily into place, then check to make sure the ball is in the open position.
 8. Clean and inspect the cover gasket recess in the valve body and cover. Inspect the cover gasket. If it is damaged, then replace the cover gasket.
For more information, see [Replace the cover gasket](#) (page 11).
 9. Install the cover assembly onto the valve body.
-

NOTICE:

Be sure the ground spring is in place over the flat of the stem and stem shoulder. The spring should bear against the bottom of the cover and top of the ball. Be sure the stem is inserted into the ball and the cover gasket is properly in place. To avoid damage to the gasket, place the gasket on the cover and install the cover (with gasket) onto the body.

10. Install and tighten the cover bolts.
For more information, see [Tighten the cover bolts](#) (page 7).
11. Cycle the valve several times.
12. If the valve has been removed from the pipeline for maintenance, then reinstall the valve.
For more information, see [Install the ball valve](#) (page 6).

Troubleshooting

Ball valve operation troubleshooting

Symptom	Cause	Remedy
The ball is locked or the seat rings or ball and stem are damaged	Media crystallization	Heat trace the valve
The flange connection between the valve flanges and pipeline or body halves are leaking	Connection is too loose	Tighten the screw connections If the connection continues to leak, then you may exceed the recommended torque by 10%. If the connection continues to leak, then disassemble and inspect the ball valve.
Leakage observed past the stem seal	Stem seal nut is too loose	Tighten the stem seal nut in accordance with the Stem seal nut torque.
Actuated valve does not operate	The actuator does not have any power	Supply power to the actuator
	If the valve is pneumatically actuated, then the solenoid is not connected	Connect the solenoid
Valve does not operate	A foreign matter is in the ball valve	Remove the foreign matter from the ball valve
Ball will not fully close	The ball and stem are deformed	Replace the ball, seat rings, and stem
	The actuator's coupling is worn	Replace the actuator's coupling
Cover gasket leaks	Cover bolts are loose	Evenly tighten all cover bolts using the criss-cross method in accordance with the Cover bolt torque.
	Cover gasket is damaged	Replace the cover gasket

For more information see:

- [Tighten the stem seal nut](#) (page 7)
- [Tighten the cover bolts](#) (page 7)

Parts Listings and Cross-Sectional Drawings

Drawing and parts list

Exploded view

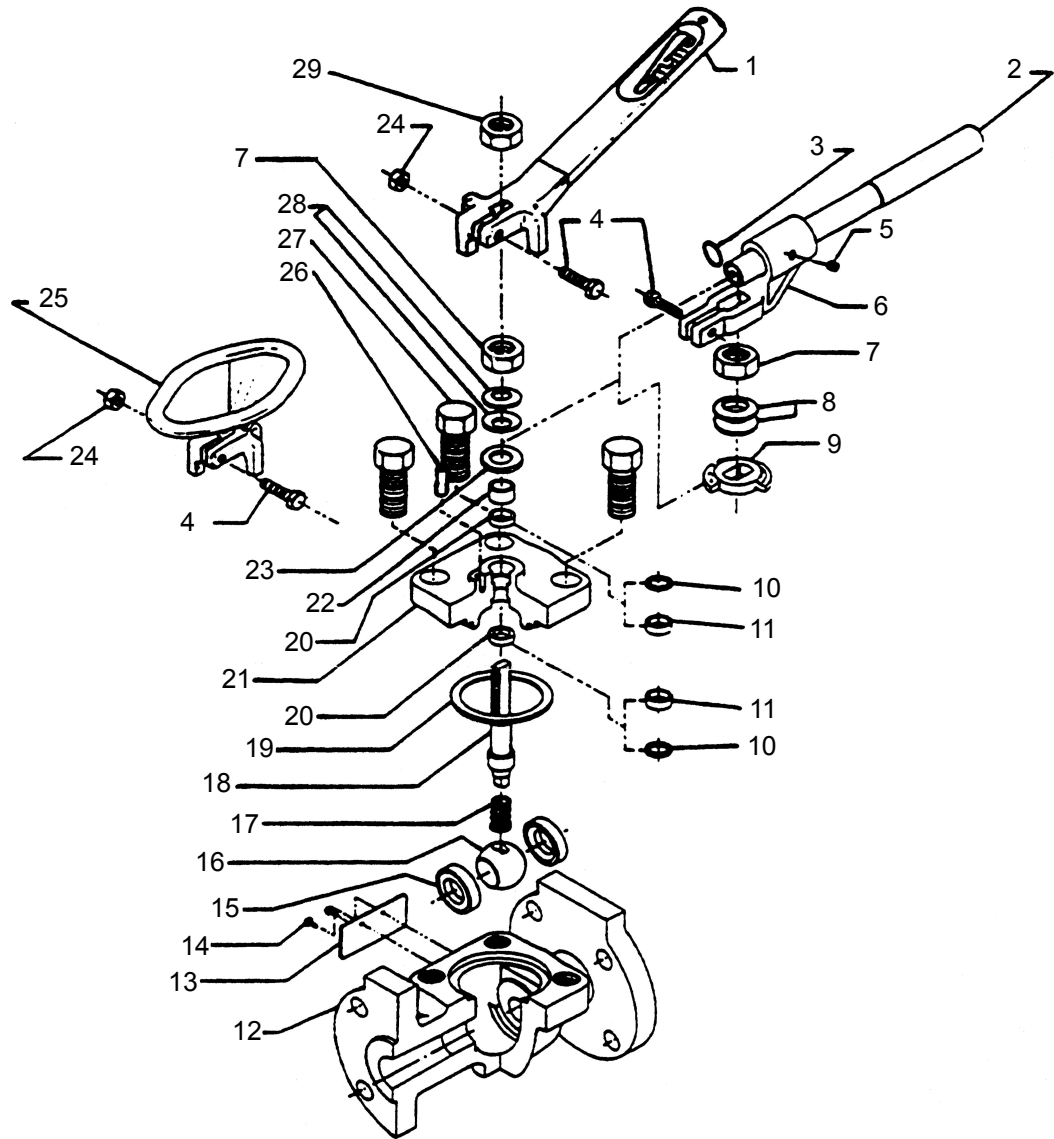

Parts list

Item	Description
1	Handle assembly (0.5–2 in. valves)
2	Handle (3–6 in. valves)
3	Safety ring
4	Screw
5	Set screw
6	Handle hub (3–6 in. valves)

Item	Description
7	Stem seal nut
8	Spring washer
9	Stop (3–6 in. valves)
10	Fire-safe bearing
11	Fire-safe stem seal
12	Body
13	Identification tag
14	Drive screw
15	Seat assembly
16	Ball
17	Spring, grounding
18	Stem
19	Gasket
20	Stem seal
21	Cover
22	Gland ring
23	Washer (0.5–2 in. valves)
24	Nut
25	Oval handwheel (0.5–2 in. valves)
26	Grooved pin, stop
27	Cap screw
28	Spring washer
29	Hex jam nut (0.5–2 in. valves)



ITT

Visit our Web site for the latest version of this document and more information
<http://www.engvalves.com>

Engineered Valves
33 Centerville Road
Lancaster, PA 17603
USA
Tel. (717) 509-2200
Fax (717) 509-2316
E-mail: engvalves.custserv@itt.com