

Straightway Valves

Features and Benefits

Ideal for slurry, abrasive and corrosive applications, the Dia-Flo Straightway Diaphragm Valve provides the following benefits:

- **Slurry Applications:** Due to the streamlined fluid passage, the Dia-Flo Straightway Valve can handle slurries, without solid particles becoming entrapped in cavities or crevices which may obstruct the operation of other valve types. In addition, the unobstructed flow path allows the valve to be rodded through.
- **Abrasion Resistant:** Available in five rubber linings: Soft Rubber, Hard Rubber, Neoprene®, Hypalon® and Butyl, the Straightway Valve is well suited to handling corrosive and abrasive services.
- **Corrosion Resistant:** In addition to the rubber linings, ETFE and polypropylene linings are available to handle the most corrosive services. To protect the valve exterior, PVDF and white epoxy coatings are available.
- **Conventional Straightway Design:** The Dia-Flo Straightway Valve is a conventional design as opposed to a reduced port straightway design. A reduced port straightway design is similar to a pre-pinched pinch valve, in that the flow path cross-sectional area is generally reduced. The reduction in area results in reduced flow capacity (Cv), increased velocity, increased pressure drop and accelerated wear through the valve.

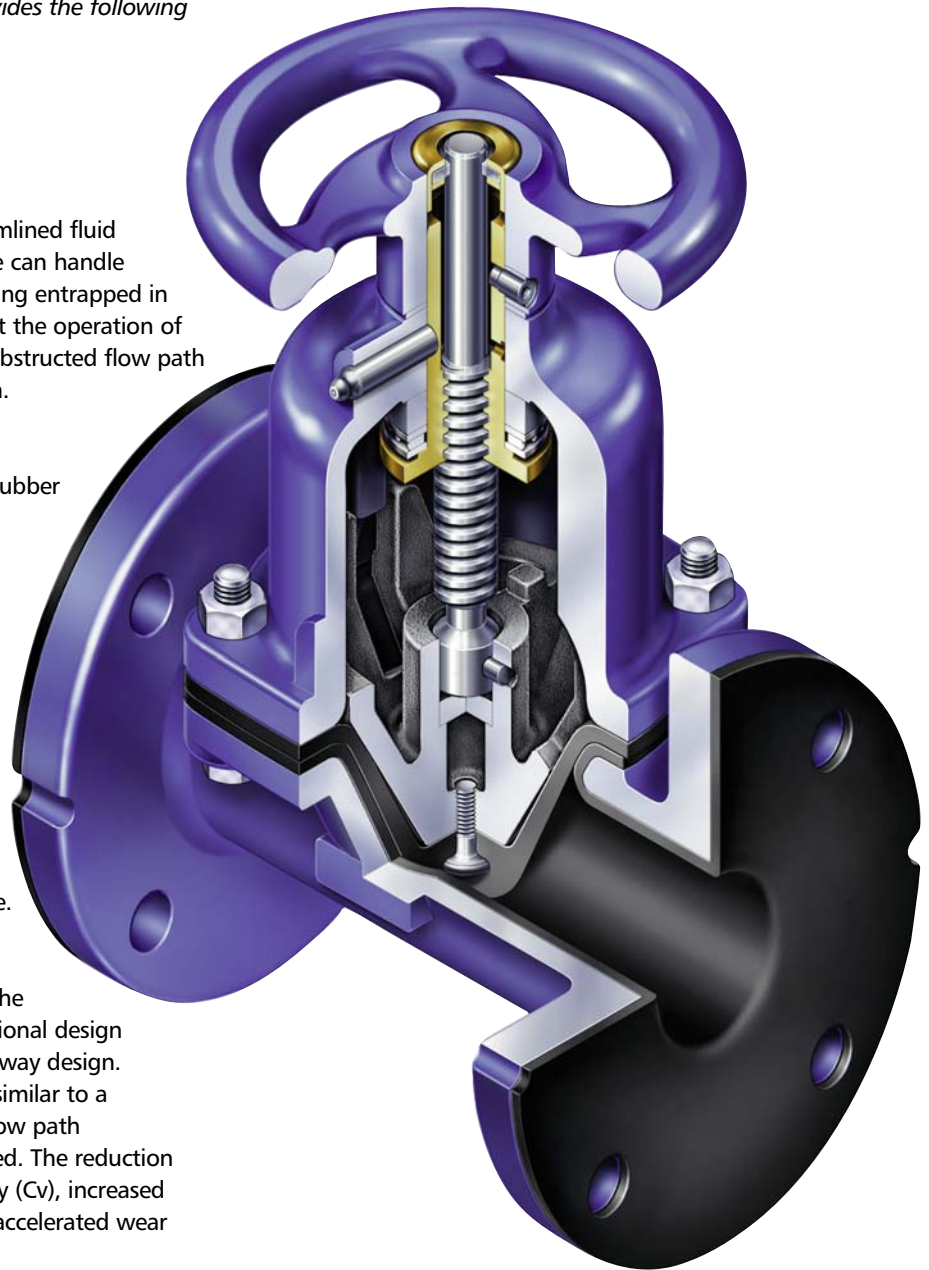

Straightway Valves

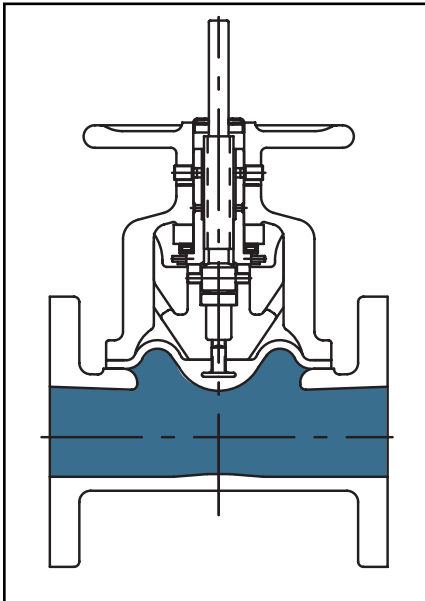

VALVE OPEN

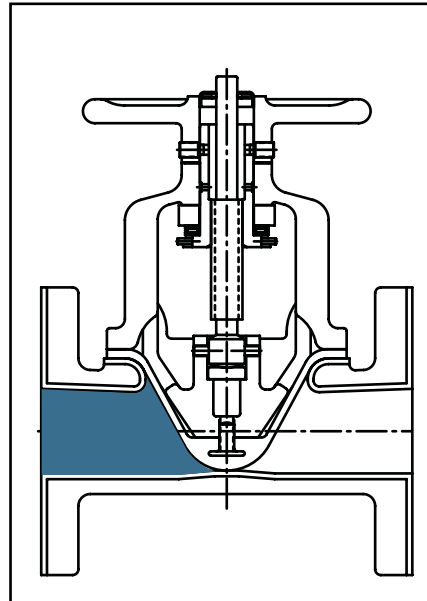

VALVE CLOSED



VALVE OPEN

Additional Features

- Can be rodded out in either direction
- Unimpeded Flow
- Negligible pressure drop
- Self draining when piping is pitched

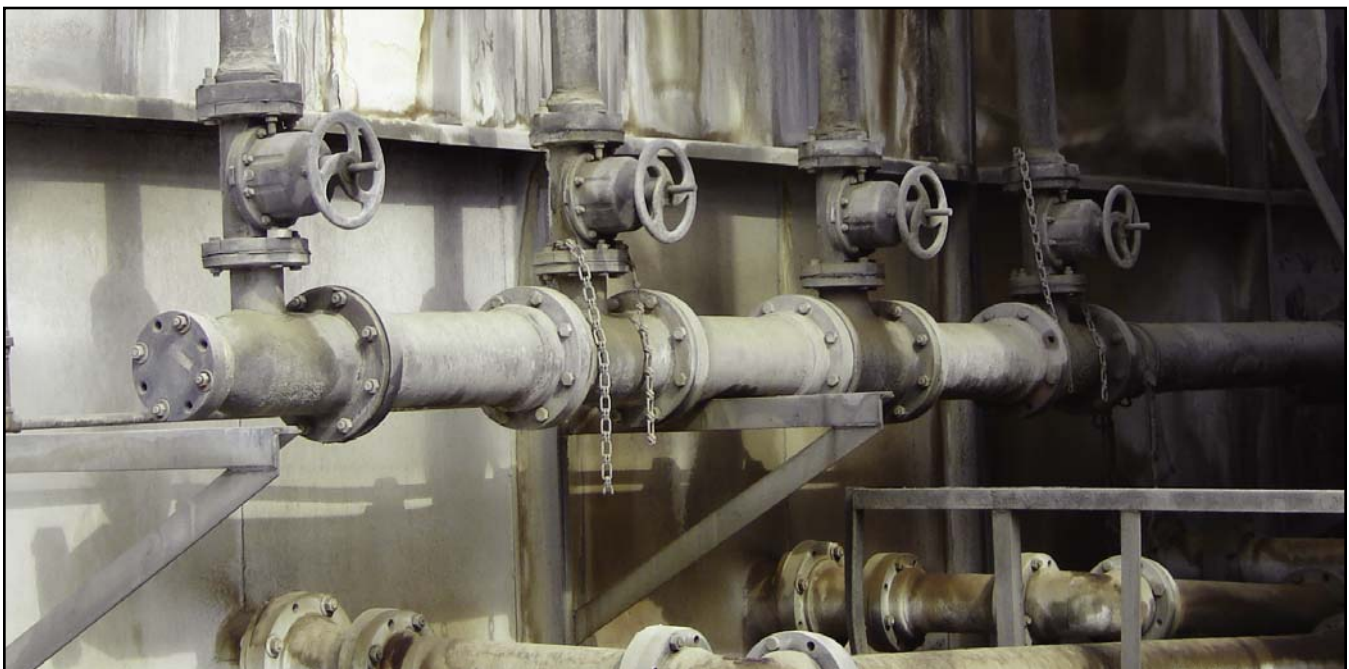

Straightway rubber lined valves in phosphoric acid service.

Straightway Valve Selections

Unlined Metal

Flanged Metal

1"-12"	Cast Iron	2811
1"-12"	Ductile Iron	2812

Raised Face Flanged Metal

1"-8"	Stainless Steel	2813R
1"-8"	Cast Steel	2815R

Maximum temperature for all of the above configurations is 225° F, (107° C)

- Excellent CVs
- Flanged or Raised face flanges
- ASTM materials include:
 - Cast Iron ASTM A-126 Class B
 - Ductile Iron ASTM A-395 Grade 60-40-18
 - Stainless Steel ASTM A-351 Grade CF8M
 - Cast Steel ASTM A-216 Grade WCB

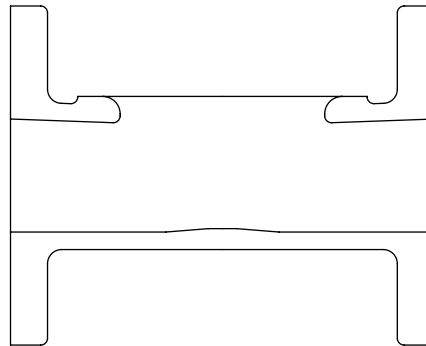

Plastic Lined

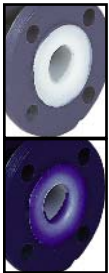

- **ETFE** ...Suitable for strong acids and solvents. Compatible with a very broad range of chemicals under a wide range of conditions. Maximum temperature 225° F (107° C)¹
- **Polypropylene**...Especially suitable for organic solvents degreasing agents, excellent resistance to alkalines...economically priced, poor resistance to Chlorinated solvents. Maximum temperature 200° F (93° C)¹

- Superior Flow Characteristics
- 3/16" Minimum Lining Thickness
- Excellent Corrosion Resistance

Flanged Plastic Lined

1"-8"	Tefzel (C.I.)	2829
1"-8"	Polypropylene (C.I.)	2838
1"-8"	Tefzel (D.I.)	2859

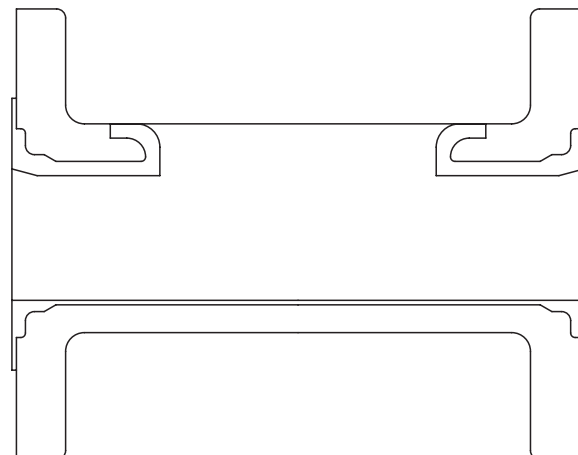

¹ Temperature may decrease dependent upon media, pressure and valve size.

Straightway Valve Selections

Rubber Lined



- Neoprene**...A synthetic base elastomer with some physical properties similar to natural rubber. Superior to natural rubber in resistance to heat, ozone, sunlight and oil. Typical applications include: phosphoric acids; magnesium oxide and sodium hydroxide.
 Maximum temperature 200° F (93° C)¹



- Soft Rubber**...Good resistance to most inorganic chemicals with the exception of strong oxidizing agents. Exhibits outstanding abrasion resistance. Typical applications include: gypsum, flyash, titanium dioxide slurries and sewage.
 Maximum temperature 180° F (82° C)¹



- Hard Rubber**...Better chemical and heat resistance than soft rubber. Wide application in organic and inorganic acids and chlorine gas. Typical applications include: potable water; oxidizing agents; plating solutions; salts; sludge and ferric chloride.
 Maximum temperature 200° F (93° C)¹



- Hypalon***...Good resistance to high concentrations of sulfuric and nitric acids. Good heat, weather, ozone and abrasion resistance. Other typical applications include: nickel plating solutions and ferric chloride.
 Maximum temperature 200° F (93° C)¹



- Chlorobutyl**...Good heat resistance. Unaffected by cold weather or rapid temperature changes. Typical applications include: hydrofluoric acid, various zinc solutions and fertilizer solutions.
 Maximum temperature 200° F (93° C)

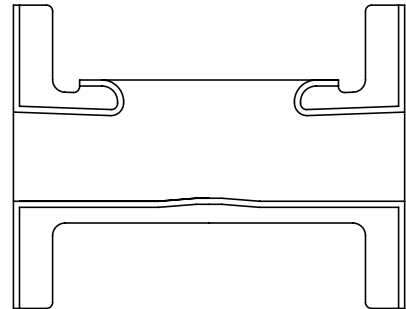

- 1/8" Minimum Lining Thickness
- Cast Iron or Ductile Iron available
- Excellent for slurries and abrasive applications



Flanged Rubber Lined Cast Iron

1"-12"	Neoprene #7	2831
1"-12"	Soft Rubber #5	2833
1"-12"	Hard Rubber #10	2834
1"-12"	Hypalon #9	2835
1"-12"	Chlorobutyl #16	2836

Ductile Iron

1"-12"	Neoprene #7	2840
1"-12"	Soft Rubber #5	2841
1"-12"	Hard Rubber #10	2842



¹ Temperature may decrease dependent upon media, pressure and valve size.

Hypalon is a registered trademark of E.I DuPont de Nemours and Co. Inc.

Straightway Valve Selections

STRAIGHTWAY DIAPHRAGMS



Grade	Material	Size	Temperature ¹	Typical Services
Grade SB	Black Butyl (FDA Compliant)	1-4"	0 to 200°F (-18 to 93°C)	Chemicals, stronger acids
Grade SC	Hypalon®	1-4"	0 to 180°F (-18 to 82°C)	Oxidizing fluids, oil resistant
Grade SE	EPDM (FDA Compliant)	1-12"	-20 to 225°F (-29 to 107°C)	Chemicals, acids, hi-temp, abrasives
Grade SP*	Buna N® NBR (FDA Compliant)	1-6"	10 to 180°F (-12 to 82°C)	Foods, oils
Grade SS	Natural Rubber	1-12"	-20 to 180°F (-29 to 82°C)	Water, abrasives
Grade ST	Neoprene®	1-12"	-10 to 180°F (-23 to 82°C)	Weak chemicals, air, oil

*2.5" not available

¹ Diaphragms at maximum temperature cannot be used satisfactorily at maximum pressures.

Bonnet Assemblies for Straightway Manual Valves

Straightway bonnet assemblies include:

- Indicating Stem
- Bronze Bushing
- Lubrication Fitting
- Cast Iron Bonnet Shell and Handwheel

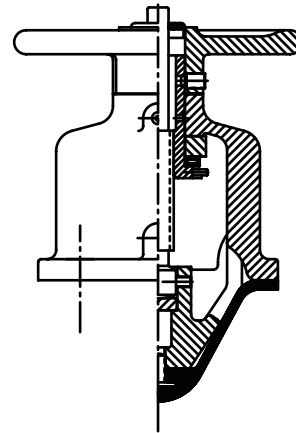

902 Bonnet Assembly

Manual Valve Bonnet Assembly Options

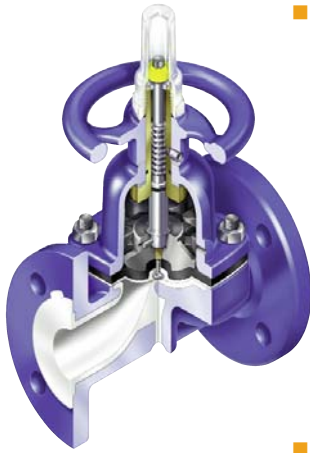

"O" Ring Sealed Bonnet

- **"O" Ring Sealed Bonnet...**Provides a secondary seal which retains fluids or gases within the valve bonnet in the event of diaphragm failure. A standard sealed bonnet is recommended for hazardous materials which will not damage bonnet shell, bushing or spindle (stem). On corrosive fluids or gases, either non-sealed bonnets or in cases where the fluids or gases must be contained, more corrosion resistant materials should be utilized. All sealed bonnets are provided with v-notch vent plugs to provide a safe and easy method of checking diaphragm integrity.

If a sealed bonnet is used and the bonnet assembly cannot handle the line media for a prolonged period of time, contact ITT for recommendations.

- **Handwheel Locking Device...**Secures valve in position so that it may not be operated unless unlocked and disengaged.
- **Chain Wheel Operated...**Uses standard sprocket rim, guide and chain. Available 1/2"-12", weir or straightway.
- **Extended Stem...**Available in all sizes. Not available with solid plastic bodies.
- **Direct Loaded Bonnet...**An inexpensive approach to automatic on-off operation. Ideal for multi-valve panel operation of batching systems, water and waste treatment systems. Furnished with or without pilot solenoid utilizing pneumatic or hydraulic operation. Available in sizes 1/2"-3" for pressures up to 100 psi. Suitable for all standard weir body materials.
- **Other Available Options...**
 - Stainless Steel
 - Ductile iron
 - Bronze
 - PAS (polyarylsulfone) plastic
- **Gear Boxes...**Especially suitable for large size valves with high line pressures this accessory reduces the amount of force required to manually operate the valve.
- **Vacuum Preparation...**Dia-Flo diaphragm valves are capable of bubble-tight shut-off down to 0.1 micron. Elastomer or PTFE diaphragms may be used. The standard weir valve design with elastomer diaphragm is capable of in-leakage of less than 1×10^{-6} atm-cc/sec, and on special order it can be furnished with a substantially lower in-leak rate.



Handwheel Locking Device



Chainwheel Operated



Extended Stem

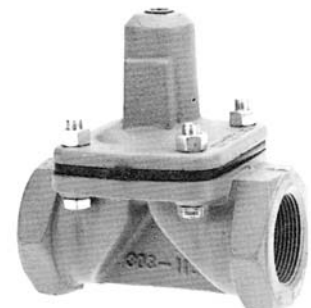

Direct Loaded Bonnets
See Actuator Section for Detail

www.engvalves.com