

## Typical Services

### Corrosion

The thousands of combinations of valve body materials and diaphragms offer a practical solution to almost any corrosive fluid. Enhanced materials technology provides us with the ability to handle your corrosive applications at increased temperatures. Optional Dia-Flo diaphragm valves with ANSI B16.10 face-to-face dimensions can act as a direct replacement to ball or plug valves without the need to modify your piping system. Additionally, any combination will provide the basic design features of in-line maintenance, bonnet isolation and positive, bubble tight closure.

### Abrasion

Hundreds of combinations of abrasion resistant diaphragms and body linings are available to solve abrasive problems. The fluid contacts only the abrasion resistant diaphragm and body or lining because the diaphragm isolates the working parts from the process fluids.

### Clogging

Viscous fluids, fibrous slurries and other materials requiring full flow valve characteristics pass directly through the Dia-Flo straightway diaphragm valve. The diaphragm lifts high into the bonnet offering negligible resistance to flow in either direction, thus eliminating any possibility of clogging. Conversely, positive closure is assured by the large area of contact between the resilient diaphragm and the body. Diaphragm valves are self-draining and self-cleaning.

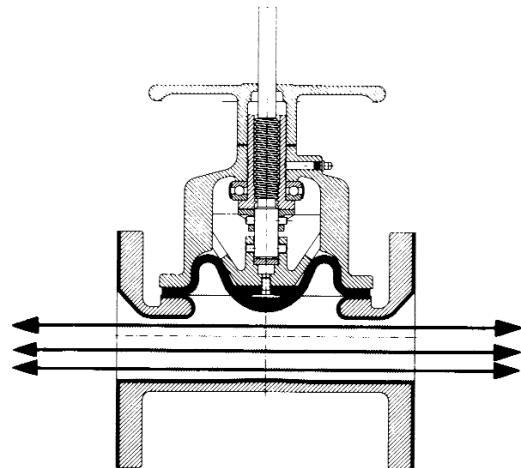
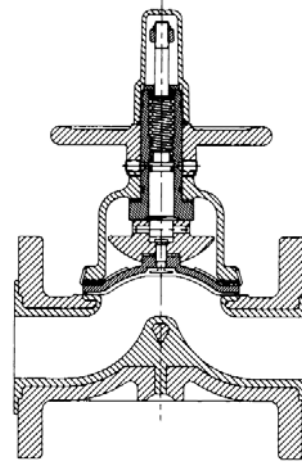

## Typical Services

### Vacuum and Gas Handling

Stem leakage is improbable because the diaphragm completely seals the bonnet from the gas traveling through the valve body. Furthermore, absolute closure of the valve greatly reduces the possibility of gas leakage when in the closed position. These features, combined with low gas permeability, make the Dia-Flo weir diaphragm valve especially suitable for gas and/or vacuum services.

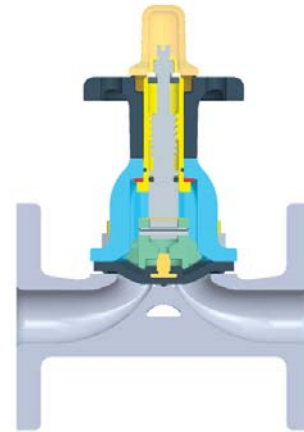

### Contamination

The inherent features of the diaphragm valve make it an ideal candidate for applications where contamination potential must be eliminated. The valve diaphragm isolates the working parts of the bonnet assembly from the process fluids. These valves can be cleaned in place without removal from the pipeline and have no cavities or pockets to trap process or cleaning fluids.

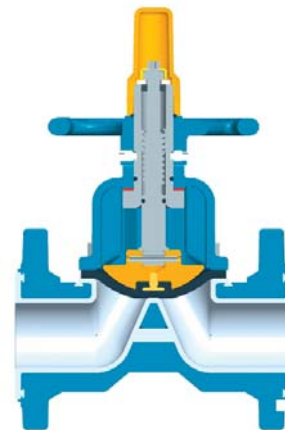

### Control

Precision throttling of highly corrosive or abrasive media is provided by the Dualrange® diaphragm valve. A double compressor assembly acts as a valve within a valve. At low flow rates, the contoured center of the diaphragm is operated by the inner compressor for accurate control. When the inner compressor is fully opened, both compressors move as a single unit to deliver full flow capacity.

