

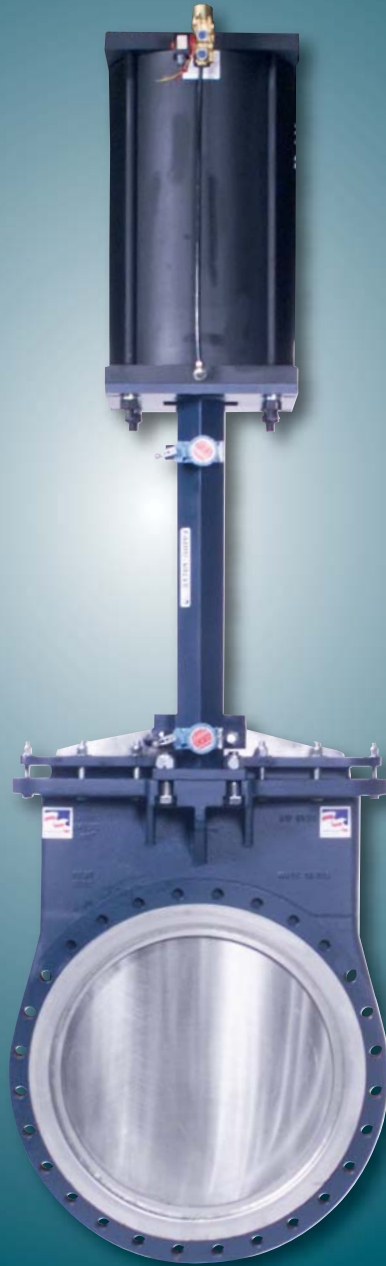

ITT

Fabri-Valve®

Lined Knife Gate Valve



Engineered for life

Figure C37L

Revision 3

Fabri-Valve® C37L Lined Knife Gate Valve

The Fabri-Valve C37L offers the corrosion resistance of a stainless steel lining with the economy of a cast iron body. The body and chest are lined with a choice of 304, 316 or 317L stainless steel. Fabri-Valve lined valves feature fully supported liners that are vacuum leak tested during manufacture. Meets or exceeds specifications MSS-SP-81 and Tappi 405-8.

Specifications

Size Range
30" & 36"

Pressure Rating
150 psi (10.3 bar) CWP (cold working pressure)

Temperature Rating
450°F (232°C). Service temperatures above 400°F (204°C) require high temperature fasteners. Specify service temperature on paperwork.

Flange Drilling
ANSI 125/150

Testing

Every Fabri-Valve Figure C37L valve is fully tested prior to shipment. Testing includes a body shell test, a seat test, and a cycling test to insure proper functioning of moving parts. Additional testing is also available. Please let us know your requirements.

Standard Shell test:

- Hydro test at 1.5 times the rated CWP (cold working pressure) – Zero allowable leakage

Standard Seat test:

- Metal Seat: Hydro test at 40 psi (2.8 bar) and at the rated CWP
- Resilient Seat: Hydro test at 15 psi (1 bar) and rated CWP

Shutoff Performance

Metal Seat

- Single integral metal seat
30" & 36" 60cc / minute / inch of valve size

Resilient Seat

- Single "D" ring Zero leakage all sizes

Available Options

- "D" Ring Seat
- Epoxy Coating
- Thru Drilled Flanges
- V-Port
- Locking Devices
- Live Loaded Packing
- Self-Supporting Yoke
- Bevel Gear
- Centerline Buttons
- Backing Rings
- Deflection Cones
- Chainwheels
- Cylinder Actuators
- Electric Actuators
- Ratchet
- Extended Stems
- Gate Support Strips
- Rod Boots

Pressure/Temperature Ratings

The table below is the Maximum Pressure Temperature Ratings for the metallic components only. When checking pressure/temperature ratings, check the temperature rating and chemical compatibility of the packing material, and if applicable, the resilient seat material. In a majority of knife gate valve designs, the temperature limit or the chemical compatibility of the seat and/or packing material determines the practical pressure/temperature limitations.

Temp		Pressure/Temperature Rating - psi (bar)
°F	°C	
150	66	150 (10.3)
200	93	141 (9.7)
250	121	132 (9.1)
300	149	122 (8.4)
350	177	113 (7.8)
400	204	104 (7.2)
450	232	94 (6.5)

Flow Coefficients

The Cv values below represent U.S. gallons per minute 60°F water through a 100% open valve at a pressure drop of 1 psi. The metric equivalent, Kv, is the flow of water at +16°C through the valve in cubic meters per hour at a pressure drop of 1 kg/cm². To convert Cv to Kv, multiply the Cv by 0.8569.

Cv Ratings			
Valve Size		Metal Cv	D-Ring Cv
Inches	DN		
30	750	53,950	54,450
36	900	77,800	79,600

Materials of Construction

Part	Material
Body, Chest and Flanges	One piece cast iron body, chest and flanges lined with 304, 316 or 317L stainless steel. Flanges have smooth stainless steel raised faces.
Seat	Stainless steel or optional "D" ring
Gate	Same grade stainless steel as liner, finished to 63 RMS
Yoke	Carbon steel
Yoke Fasteners	Plated steel
Stem	304 Stainless steel
Stem Nut	Acid resistant bronze
Lubrication Fitting	Plated steel
Packing	Acrylic/PTFE/Silicone
Packing Follower	Carbon steel with plated steel bolting
Handwheel	Cast iron
Handwheel Nut	Malleable iron
Tab Washer	Stainless steel

Dimensions

Valve Size		DIMENSION Inches (mm) C37L with HANDWHEEL OR CYLINDER																	Weight*					
Inches	DN	A			C			D		H	J	K	L	M	N	P	R	S	T	V	W	AA	lb	kg
30	750	HW	14 CYL	16 CYL	HW	14 CYL	16 CYL	14 CYL	16 CYL															
		98-5/16 (2497)	103-1/16 (2718)	103-9/16 (2630)	30 (762)	14-3/4 (375)	17 (432)	3/4-14	3/4-14	27-3/8 (695)	38-3/4 (984)	7/8 (22)	10	1-1/4-7NC	28	36 (914)	33-3/4 (857)	16 (406)	1/8 (3)	1-3/16 (30)	4-5/8 (117)	29-1/2 (749)	1600	726
36	900	HW	16 CYL	18 CYL	HW	16 CYL	18 CYL	16 CYL	18 CYL															
		116-1/4 (2953)	121-3/8 (3083)	123-1/4 (3131)	30 (762)	17 (432)	19 (483)	3/4-14	3/4-14	32-7/8 (835)	46 (1168)	1-7/32 (31)	12	1-1/2-6NC	32	42-3/4 (1086)	40-1/4 (1022)	20 (508)	1/8 (3)	1-1/2 (38)	5-3/4 (146)	35-1/2 (902)	2134	968

* Valve with Handwheel

Reference Dimensions in (parentheses)

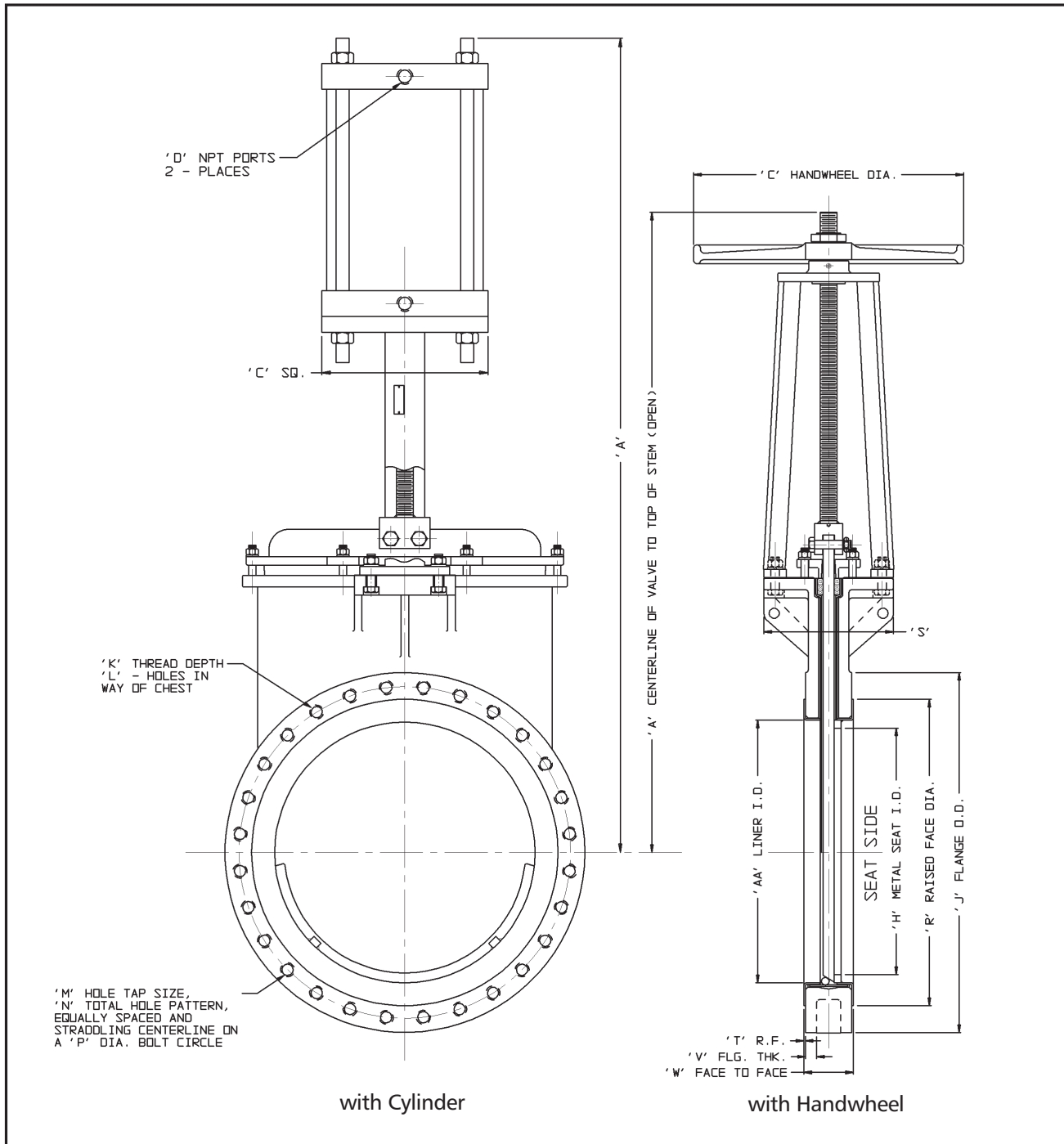

Engineered Valves

For more information contact:

Engineered Valves

1110 Bankhead Avenue

Amory, MS 38821 USA

Phone: (800) 541-1849

(662) 256-7185

Fax: (662) 256-7932

Web site: www.engvalves.com

E-mail: engvalves.custserv@itt.com



Engineered for life

© 2007 ITT Corporation