



ITT

Fabri-Valve®

Bi-Directional Knife Gate Valve



Engineered for life

Figure C67

Revision 4

Fabri-Valve® C67 Bi-Directional Knife Gate Valve

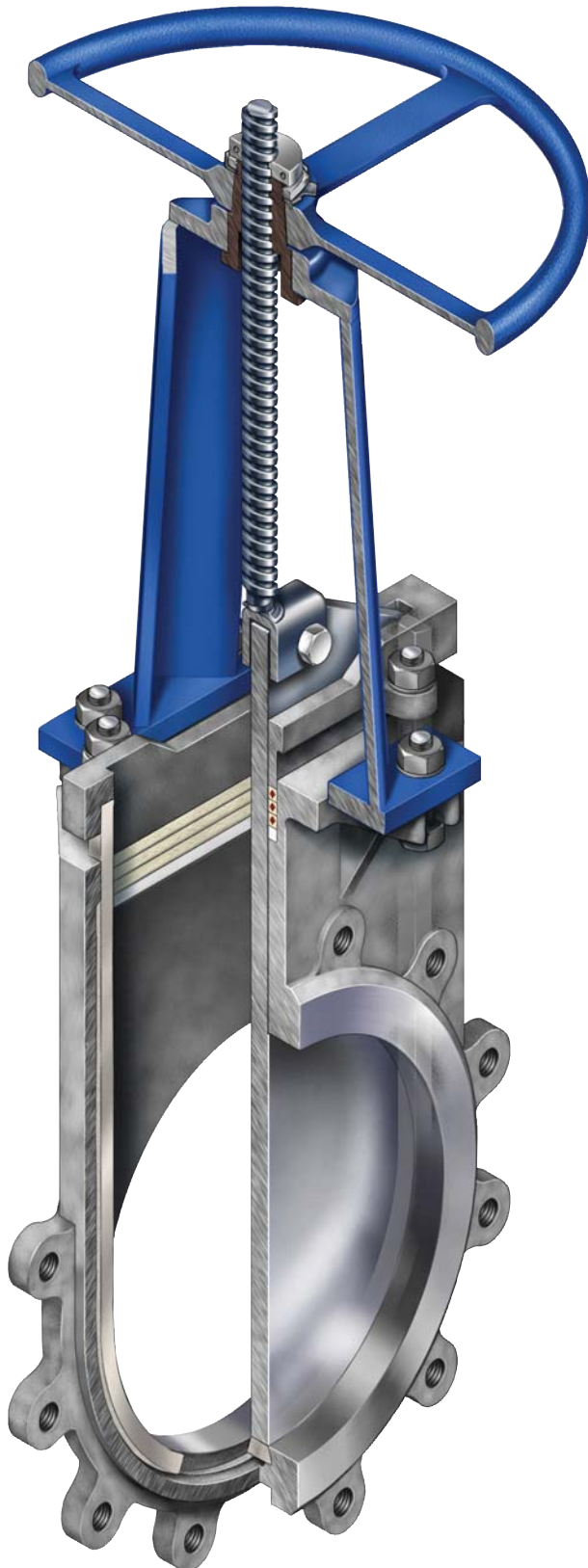

Energized cored packing and packing supports are standard with 6" (DN 150) and larger Figure C67 valves

The Fabri-Valve Figure C67 features a unique, patented*, perimeter seal that provides bi-directional shutoff. The seal is retained in the valve body by its trapezoidal shape. A relief has been cast into the valve body behind the seal. Designed to overcome the problems experienced with existing perimeter seal designs, the relief greatly reduces seal compression set; the shape of the seal eliminates leakage due to seat rollover, eliminates seal pullout due to fluid velocity, and eliminates grooves that collect material and prevent the valve from properly closing. This unique valve design is available in stainless steel and carbon steel. Stainless steel bodied valves have white EPDM seals as standard. Carbon steel bodied valves have black EPDM seals as standard. Black Viton or white Viton, AFLAS, Hycar, Hypalon, Neoprene, HNBR, and other seal materials are available as options.

All Figure C67 handwheel actuated knife gate valves include a provision for a locking device.

Specifications

Size Range

2" – 36"

Pressure Rating

2" – 24" 150 psi (10.3 bar) CWP (cold working pressure)

30" 100 psi (6.9 bar)

36" 80 psi (5.5 bar)

Consult factory for higher pressure designs.

Temperature Rating

EPDM Seat -50°F (-45°C) to 280°F (138°C)

Viton Seat -30°F (-34°C) to 350°F (177°C)

Flange Drilling

ANSI 125/150 Drilling

Testing

Every Fabri-Valve Figure C67 valve is fully tested prior to shipment. Testing includes a body shell test, a seat test and a cycling test to insure proper functioning of moving parts. Additional testing is also available. Please let us know your requirements.

- Standard Shell test: Hydro test at 1.5 times the rated CWP (cold working pressure) – Zero allowable leakage
- Standard Resilient Seat test: Hydro test at 15 psi (1 bar) and rated CWP

*U.S. Patent #5, 154,397

Pressure/Temperature Ratings

The table below is the Maximum Pressure Temperature Ratings for the metallic components only. When checking pressure/temperature ratings, check the temperature rating and chemical compatibility of the packing material and the resilient seat material. In a majority of knife gate valve designs, the temperature limit or the chemical compatibility of the seat and/or packing material determines the practical pressure/temperature limitations.

Figure C67							
Pressure-Temperature Rating -psi							
Temp		Cast 304	Cast 304L	Cast 316	Cast 316L	Cast 317L	Cast WCB A-216
°F	°C						
150	66	150	150	150	150	150	150
200	93	142	142	150	150	135	150
250	121	135	135	142	142	128	150
300	149	129	129	134	134	121	150
350	177	123	123	128	128	116	150
400	204	118	118	123	123	112	150
450	232	114	114	118	118	108	150
500	260	111	111	114	114	105	150

Shutoff Performance

Zero leakage. All sizes.

Flow Coefficients

The Cv values below represent U.S. gallons per minute 60°F water through a 100% open valve at a pressure drop of 1 psi. The metric equivalent, Kv, is the flow of water at +16°C through the valve in cubic meters per hour at a pressure drop of 1 kg/cm². To convert Cv to Kv, multiply the Cv by 0.8569.

Figure C67 Knife Gate Valves							
Cv, Ratings, Port Diameter and Area							
		Standard Port			With V-Seat		
Valve Size In.	DN	Cv	Port I. D. Inches	Port Area Sq. In.	Cv	Port I. D. Inches	Port Area Sq. In.
2	50	288	2.00	3.1	165	2.00	2.8
3	75	648	3.00	7.1	355	3.00	6.3
4	100	1,152	4.00	12.6	515	4.00	9.5
6	150	2,592	6.00	28.3	1,350	6.00	24.9
8	200	4,608	8.00	50.3	2,050	8.00	38.1
10	250	7,208	10.00	78.5	3,200	10.00	59.0
12	300	10,400	12.00	113.1	4,450	12.00	82.3
14	350	12,650	13.25	137.9	5,350	13.25	98.8
16	400	16,750	15.25	182.6	6,950	15.25	128.4
18	450	21,450	17.25	233.7	10,700	17.25	198.2
20	500	26,700	19.25	291.0	13,250	19.25	245.4
24	600	38,900	23.25	424.6	15,400	23.25	284.7
30	750	61,600	29.25	671.9			
36	900	89,460	35.25	975.9			
					Consult Factory		

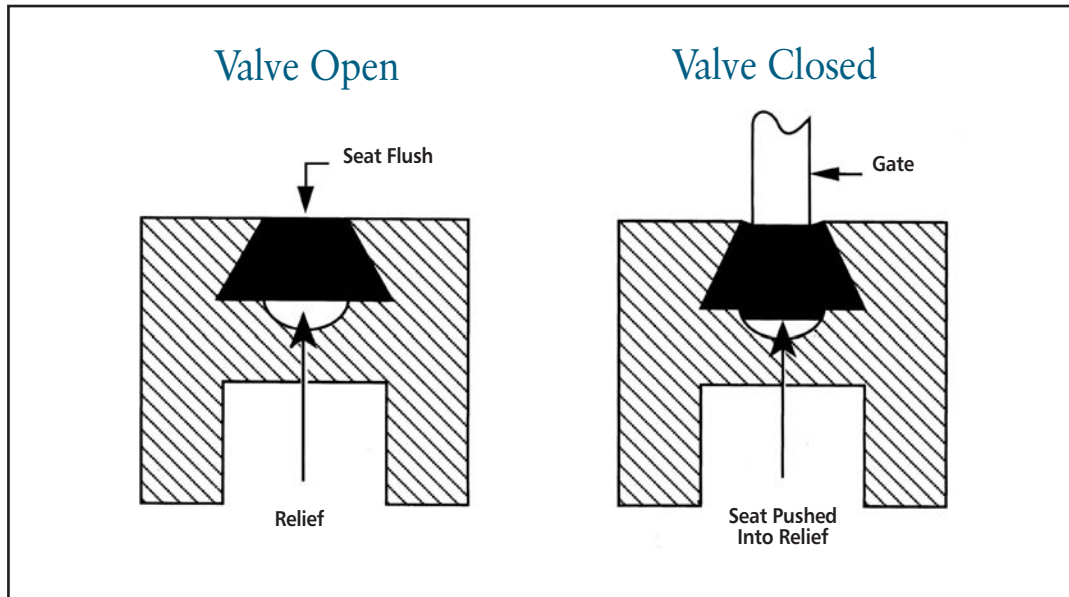

Fabri-Valve® C67 Bi-Directional Knife Gate Valve

Dimensions

Valve Size		TABLE 1 DIMENSION Inches (mm) C67 with HANDWHEEL OR CYLINDER																	Weight *				
Inches	DN	A			C			D		H	J	K	L	M	N	P	R	S	T	V	W	lb	kg
		HW	2-1/2 CYL	3-1/4 CYL	HW	2-1/2 CYL	3-1/4 CYL	2-1/2 CYL	3-1/4 CYL														
2	50	14-7/8 (378)	18-3/16 (462)	16-7/16 (418)	10 (254)	3 (76)	4 (102)	3/8-18	1/4-18	2 (51)	6 (152)	27/64 (11)	2	5/8-11NC	4	4-3/4 (121)	3-5/8 (92)	4 (102)	1/16 (2)	9/16 (14)	1-7/8 (48)	17	8
3	80	17-5/8 (448)	20-11/16 (525)	19-3/16 (487)	10 (254)	3 (76)	4 (102)	3/8-18	1/4-18	3 (76)	7-1/2 (191)	23/64 (9)	2	5/8-11NC	4	6 (152)	5 (127)	4 (102)	1/16 (2)	9/16 (14)	2 (51)	21	10
4	100	19-13/16 (503)	21-15/16 (557)	22-11/16 (576)	10 (254)	4 (102)	4-1/2 (114)	1/4-18	3/8-18	4 (102)	9 (229)	27/64 (11)	2	5/8-11NC	8	7-1/2 (191)	6-3/16 (157)	4 (102)	1/16 (2)	11/16 (17)	2 (51)	30	14
6	150	27-3/8 (695)	29-9/16 (751)	29-15/16 (760)	16 (406)	4-1/2 (114)	6-1/2 (165)	3/8-18	3/8-18	6 (152)	11 (279)	7/16 (11)	2	3/4-10NC	8	9-1/2 (241)	8-1/2 (216)	7-3/8 (187)	1/16 (2)	5/8 (16)	2-1/4 (57)	75	34
8	200	34-3/16 (868)	36-3/8 (924)	36-7/8 (937)	16 (406)	6-1/2 (165)	8-5/8 (219)	3/8-18	3/8-18	8 (203)	13-1/2 (343)	21/32 (17)	2	3/4-10NC	8	11-3/4 (298)	10-5/8 (270)	7-3/8 (187)	1/16 (2)	13/16 (21)	2-3/4 (70)	95	45
10	250	39-5/8 (1006)	42-9/16 (1081)	43-5/16 (1100)	16 (406)	8-5/8 (219)	10-7/8 (276)	3/8-18	1/2-14	10 (254)	16 (406)	9/16 (14)	4	7/8-9NC	12	14-1/4 (362)	12-3/4 (324)	7-3/8 (187)	1/16 (2)	15/16 (24)	2-3/4 (70)	139	63
12	300	46-1/4 (1175)	49 (1245)	49-3/4 (1264)	20 (508)	8-5/8 (219)	10-7/8 (276)	3/8-18	1/2-14	12 (305)	19 (483)	1/2 (13)	4	7/8-9NC	12	17 (432)	15 (381)	7-1/2 (191)	3/16 (5)	1 (25)	3 (76)	197	87
14	350	51-9/16 (1310)	55-1/16 (1399)	56-3/16 (1427)	20 (508)	12-3/4 (324)	14-3/4 (375)	1/2-14	3/4-14	13-1/4 (337)	21 (533)	1/2 (13)	4	1-8NC	12	18-3/4 (476)	16-1/4 (413)	7-3/4 (197)	3/16 (5)	15/16 (24)	3 (76)	301	147
16	400	59-3/16 (1503)	62-3/8 (1584)	63-1/2 (1613)	20 (508)	12-3/4 (324)	14-3/4 (375)	1/2-14	3/4-14	15-1/4 (387)	23-1/2 (597)	5/8 (16)	6	1-8NC	16	21-1/4 (540)	18-1/2 (470)	11-1/4 (286)	3/16 (5)	1-1/16 (27)	3-1/2 (89)	379	180
18	450	66-1/2 (1689)	70-1/16 (1780)	70-11/16 (1795)	30 (762)	12-3/4 (324)	14-3/4 (375)	1/2-14	3/4-14	17-1/4 (438)	25 (635)	19/32 (15)	6	1-1/8-7NC	16	22-3/4 (578)	21 (533)	11-1/4 (286)	3/16 (5)	1-1/16 (27)	3-1/2 (89)	467	212
20	500	72-7/8 (1851)	77-1/4 (1962)	77-3/4 (1975)	30 (762)	14-3/4 (375)	17 (432)	3/4-14	3/4-14	19-1/4 (489)	27-1/2 (699)	31/32 (25)	8	1-1/8-7NC	20	25 (635)	23 (584)	14 (356)	3/16 (5)	1-3/16 (30)	4-1/2 (114)	523	237
24	600	84-3/4 (2153)	88-9/16 (2249)	90-1/2 (2299)	30 (762)	17 (432)	19 (483)	3/4-14	3/4-14	23-1/4 (591)	32 (813)	29/32 (23)	8	1-1/4-7NC	20	29-1/2 (749)	27-1/4 (692)	14-1/8 (359)	3/16 (5)	1-5/16 (33)	4-1/2 (114)	713	321
30	750	N/A	106-15/16 (2716)	108-13/16 (2764)	N/A	17 (432)	19 (483)	3/4-14	3/4-14	29-1/4 (591)	38-3/4 (984)	15/16 (24)	10	1-1/4-7NC	28	36 (914)	33-3/4 (857)	15 (381)	3/16 (5)	1-5/16 (33)	4-1/2 (114)	Consult Factory	
36	900	N/A	130-15/16 (3326)	131-11/16 (3345)	N/A	19 (483)	21 (533)	3/4-14	3/4-14	35-1/4 (895)	46 (1168)	1 (25)	12	1-1/2-6NC	32	42-3/4 (1086)	40-1/4 (1022)	19 (483)	3/16 (5)	1-3/8 (35)	5-1/2 (140)		

* Figures C67R and C67S with Handwheel

Reference Dimensions in (parentheses)

Refer to TABLE 1 for dimensions

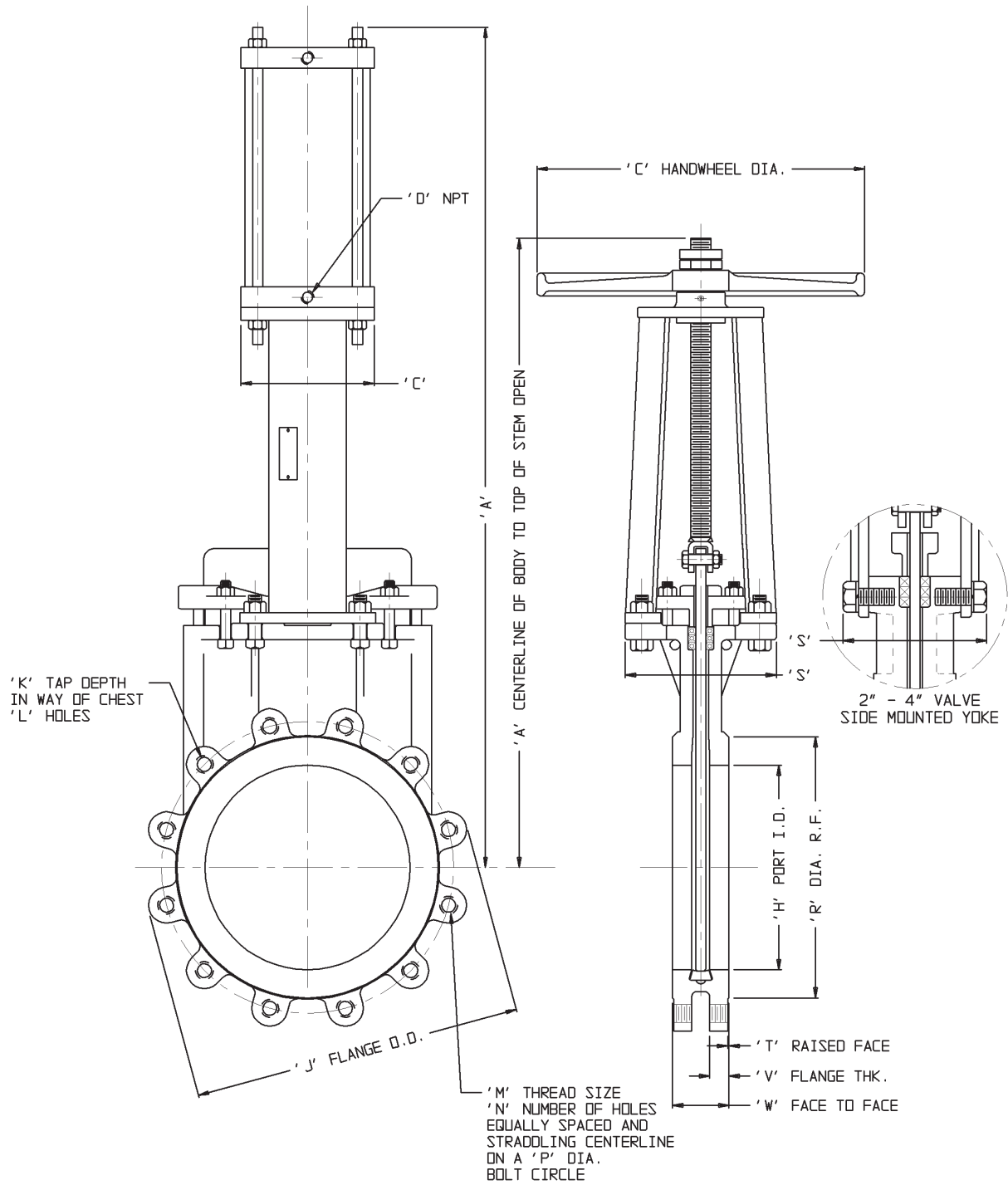

Fabri-Valve® C67 Bi-Directional Knife Gate Valve

Dimensions

Valve Size		TABLE 2 DIMENSION Inches (mm) C67 W/BEVEL GEAR																
Inches	DN	A	B	C	D	E	H	J	K	L	M	N	P	R	S	T	V	W
6	150	26-11/16 (678)	20-11/16 (525)	12 (305)	12-3/8 (314)	6-1/2 (165)	6 (152)	11 (279)	7/16 (11)	2	3/4-10NC	8	9-1/2 (241)	8-1/2 (216)	7-3/8 (187)	1/16 (2)	5/8 (16)	2-1/4 (57)
8	200	34-1/4 (870)	25-1/2 (648)	12 (305)	12-3/8 (314)	6-1/2 (165)	8 (203)	13-1/2 (343)	21/32 (17)	2	3/4-10NC	8	11-3/4 (298)	10-5/8 (270)	7-3/8 (187)	1/16 (2)	13/16 (21)	2-3/4 (70)
10	250	39-5/8 (1006)	29-1/16 (738)	12 (305)	12-3/8 (314)	6-1/2 (165)	10 (254)	16 (406)	9/16 (14)	4	7/8-9NC	12	14-1/4 (362)	12-3/4 (324)	7-3/8 (187)	1/16 (2)	15/16 (24)	2-3/4 (70)
12	300	46-1/4 (1175)	33-7/16 (849)	12 (305)	12-3/8 (314)	6-1/2 (165)	12 (305)	19 (483)	1/2 (13)	4	7/8-9NC	12	17 (432)	15 (381)	7-1/2 (191)	3/16 (5)	1 (25)	3 (76)
14	350	51-9/16 (1310)	37-1/16 (941)	12 (305)	12-3/8 (314)	6-1/2 (165)	13-1/4 (337)	21 (533)	1/2 (13)	4	1-8NC	12	18-3/4 (476)	16-1/4 (413)	7-3/4 (197)	3/16 (5)	15/16 (24)	3 (76)
16	400	59-3/16 (1503)	43 (1092)	12 (305)	12-1/16 (306)	6-1/2 (165)	15-1/4 (387)	23-1/2 (597)	5/8 (16)	6	1-8NC	16	21-1/4 (540)	18-1/2 (470)	11-1/4 (286)	3/16 (5)	1-1/16 (27)	3-1/2 (89)
18	450	66-1/2 (1689)	47 (1194)	12 (305)	12-1/16 (306)	6-1/2 (165)	17-1/4 (438)	25 (635)	19/32 (15)	6	1-1/8-7NC	16	22-3/4 (578)	21 (533)	11-1/4 (286)	3/16 (5)	1-1/16 (27)	3-1/2 (89)
20	500	72-7/8 (1851)	51-3/8 (1305)	12 (305)	12-1/16 (306)	6-1/2 (165)	19-1/4 (489)	27-1/2 (699)	31/32 (25)	8	1-1/8-7NC	20	25 (635)	23 (584)	14 (356)	3/16 (5)	1-3/16 (30)	4-1/2 (114)
24	600	84-3/4 (2029)	59-3/8 (1508)	12 (305)	12-1/16 (306)	6-1/2 (165)	23-1/4 (591)	32 (813)	29/32 (23)	8	1-1/4-7NC	20	29-1/2 (749)	27-1/4 (692)	14-1/8 (359)	3/16 (5)	1-5/16 (33)	4-1/2 (114)
30	750	106-3/16 (1851)	77-1/4 (1305)	18 (457)	12-1/16 (306)	6-1/2 (165)	29-1/4 (743)	38-3/4 (984)	15/16 (24)	10	1-1/4-7NC	28	36 (914)	33-3/4 (857)	15 (381)	3/16 (5)	1-5/16 (33)	4-1/2 (114)
36	900	129-1/16 (2153)	94 (1508)	24 (610)	12-1/16 (306)	6-1/2 (165)	35-1/4 (895)	46 (1168)	1 (25)	12	1-1/2-6NC	32	42-3/4 (1086)	40-1/4 (1022)	19 (483)	3/16 (5)	1-3/8 (35)	5-1/2 (140)

6" - 14" Valves have a bevel gear ratio of 3:1

16" - 36" Valves have a bevel gear ratio of 4:1

Reference Dimensions in (parentheses)

Materials of Construction

Part	Materials		
	C67R 2" - 36"	C67S 2" - 36"	C67R-WCB 2" - 36"
Body and Chest	Solid, one piece, cast 304, 316 or 317L stainless steel.	Solid, one piece, cast 304, 316 or 317L stainless steel.	Solid, one piece, cast carbon steel
Seat	Elastomer, white EPDM std.	Elastomer, white EPDM std.	Elastomer, black EPDM standard
Gate	Same grade as body	Same grade as body	304 stainless steel
Yoke 2" - 4" 6" - 36"	Ductile iron Carbon steel	Cast 304 stainless steel 304 stainless steel	Ductile iron Carbon steel
Yoke Fasteners	Plated steel	Stainless steel	Plated steel
Stem	304 stainless steel	304 stainless steel	304 stainless steel
Stem Nut	Acid resistant bronze	Acid resistant bronze	Acid resistant bronze
Lubrication Fitting	Plated steel	Plated steel	Plated steel
Packing	Acrylic/PTFE ¹ /Silicone	Acrylic/PTFE ¹ /Silicone	Acrylic/PTFE ¹ /Silicone
Packing Follower	Ductile iron/Carbon steel	304 stainless steel	Ductile iron
Follower Bolts	Plated steel	Stainless steel	Plated steel
Handwheel	Cast iron	Cast iron	Cast iron
Handwheel Retaining Nut	Malleable iron	Stainless steel	Malleable Iron
Tab Washer	Stainless steel	Stainless steel	Stainless steel
Travel Stop	Plated steel	Stainless steel	Plated steel

¹ PTFE/Graphite/Viton packing is standard with Viton and AFLAS seals.

Refer to TABLE 2 for dimensions

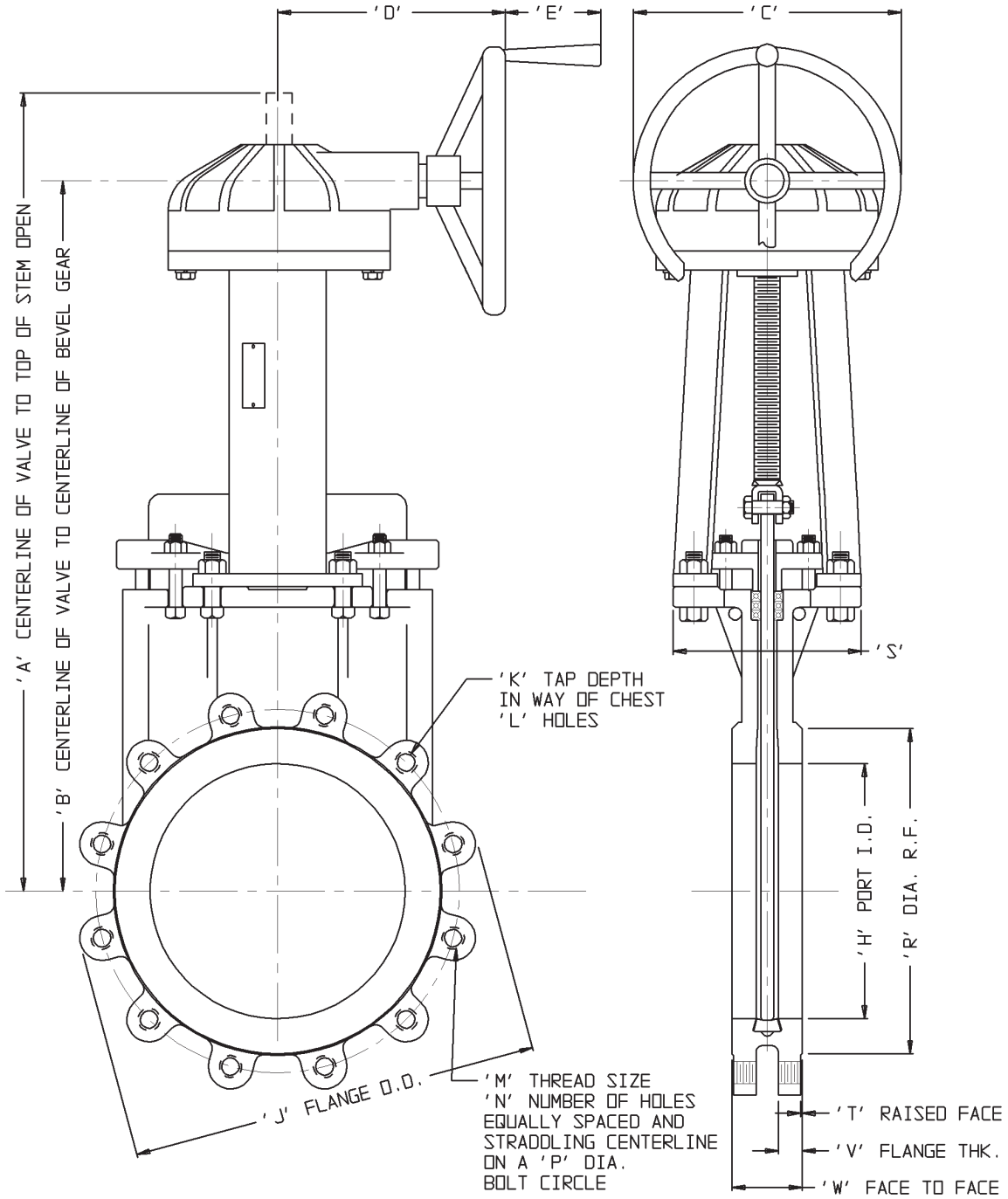

Available Options

- Hard Gate Material
- Nickel-TFE Coated Gate
- Epoxy Coating
- Thru Drilled Flanges
- Flush Ports: Chest Only, 6" (DN 150) and larger
- V-Port
- Locking Devices
- E-Z Spin Handwheel
- Live Loaded Packing
- Chest Liners
- Self-Supporting Yokes
- Alternate Flange Drilling
- Bevel Gear
- Chainwheels
- Cylinder Actuators
- Electric Actuators
- Ratchet
- Extended Stems
- Rod Boots

Chest Liners

Optional chest liners fill the clearances between the gate and the chest of the Figure C67 body. Chest liners prevent solids entrapment in the chest area, and also provide increased gate support for high flow/high pressure applications. Standard materials are ultra high molecular weight polyethylene (UHMW) and reinforced PTFE.

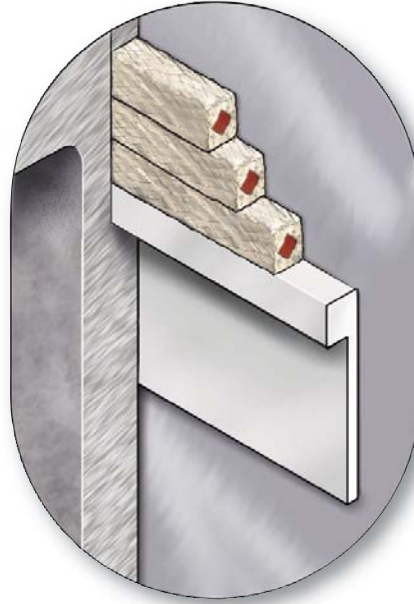

Engineered Valves

For more information contact:

Engineered Valves

1110 Bankhead Avenue

Amory, MS 38821 USA

Phone: (800) 541-1849

(662) 256-7185

Fax: (662) 256-7932

Web site: www.engvalves.com

E-mail: engvalves.custserv@itt.com



Engineered for life

© 2007 ITT Corporation