



ITT

Fabri-Valve®

Bonnetted Knife Gate Valve



Engineered for life

Figure CF134

Revision 3

Fabri-Valve® CF134 Bonneted Knife Gate Valve

The Fabri-Valve C/F134R/S bonneted knife gate valve is used in difficult services to provide high cycle stem sealing and superior stem seal containment. The cylindrical packing around the stem provides a tighter, easier to maintain stem seal. Bonneted valves are available with an optional metal backseat on the stem. In addition, the valve can be supplied with a gate wiper and purge ports in the bonnet to minimize movement of material into the bonnet. If a non-pressurized dirt shield is required, specify a Figure 37 w/dirt shroud. Standard body materials include Figure 304, 316 and 317L stainless steel. Special alloys such as 254 SMO®, Hastelloy C...are also available.

Shutoff Performance

Metal Seat

- Single integral metal seat
 - 1.5"- 24" 40cc / minute / inch of valve size
 - 25" – 48" 60cc / minute / inch of valve size
 - Above 48" consult factory
- Single hardfaced integral metal seat
 - 1.5"- 24" 80cc / minute / inch of valve size
 - 25" – 48" 120cc / minute / inch of valve size
 - Above 48" consult factory
- Single hardfaced replaceable metal seat
 - 1.5"- 24" 80cc / minute / inch of valve size
 - Above 24" consult factory
- Dual metal seats
Consult factory. All sizes

Resilient Seat

- Single "D" ring, or single replaceable resilient seat (excluding PTFE)
Zero leakage. All sizes
- Dual seats
Consult factory. All sizes
- Single replaceable PTFE seat
Consult factory. All sizes

Flow Coefficients

The Cv values below represent U.S. gallons per minute 60°F water through a 100% open valve at a pressure drop of 1 psi. The metric equivalent, Kv, is the flow of water at +16°C through the valve in cubic meters per hour at a pressure drop of 1 kg/cm2. To convert Cv to Kv, multiply the Cv by 0.8569.

Specifications

Size Range 1.5"- 96"
Pressure Rating 1.5"-24" 150 psi (10.3 bar) CWP
 Consult Factory for higher pressures.

Bonnet
 150 psi (10.3 bar) CWP standard. If a Non-pressurized dirt shield is required, use a Figure 37 w/dirt shroud.

Temperature Rating
 1.5"-48" 450°F (232°C)
 Designs available to 2000°F, Consult Factory.
 Service temperatures above 400°F (204°C) require high temperature fasteners. Specify service temperature on paperwork.

Flange Drilling
 ANSI 125/150

Testing

Every Fabri-Valve C/F134 is fully tested prior to shipment. Testing includes a body shell test, a seat test, and a cycling test to insure proper functioning of moving parts. Additional testing is also available. Please let us know your requirements.

Standard Shell test:

- Hydro test at 1.5 times the rated CWP (cold working pressure) – Zero allowable leakage

Standard Seat test:

- Metal Seat: Hydro test at 40 psi and at the rated CWP
- Resilient Seat: Hydro test at 15 psi and rated CWP

Figure C134 Bonneted Knife Gate Valves										
C _v Ratings, Port Diameter and Area										
		Standard Port			With V-Port			With Repl. Poly or Repl. Rubber seat		
Valve Size		C _v	Port I.D.	Port Area	C _v	Port I.D.	Port Area	C _v	Port I.D.	Port Area
In.	DN		Inches	Sq. In.		Inches	Sq. In.		Inches	Sq. In.
2	50	288	2.00	3.1	165	2.00	2.8	288	2.00	3.1
3	75	648	3.00	7.1	355	3.00	6.3	648	3.00	7.1
4	100	1,152	4.00	12.6	515	4.00	9.5	1,152	4.00	12.6
6	150	2,592	6.00	28.3	1,350	6.00	24.9	2,592	6.00	28.3
8	200	4,608	8.00	50.3	2,050	8.00	38.1	4,608	8.00	50.3
10	250	7,208	10.00	78.5	3,200	10.00	59.0	7,208	10.00	78.5
12	300	10,400	12.00	113.1	4,450	12.00	82.3	10,400	12.00	113.1
14	350	12,650	13.25	137.9	5,350	13.25	98.8	10,080	12.00	113.1
16	400	16,750	15.25	182.6	6,950	15.25	128.4	14,200	14.25	159.5
18	450	21,450	17.25	233.7	10,700	17.25	198.2	18,500	16.25	207.4
20	500	26,700	19.25	291.0	13,250	19.25	245.4	22,700	18.00	254.5
24	600	38,900	23.25	424.6	15,400	23.25	284.7	33,900	22.00	380.1

Dimensions

Valve Size		DIMENSION Inches (mm) C134 with HANDWHEEL															Weight**	
Inches	DN	A	C	H*	J	K	L	M	N	P	R	S	T	V	W	Y	lb	kg
2	50	18-5/8 (465)	8 (203)	2 (51)	6 (152)	3/8 (10)	2	5/8-11NC	4	4-3/4 (121)	3-5/8 (92)	6-1/4 (159)	1/16 (2)	9/16 (14)	1-7/8 (48)	5-1/8 (130)	40	18
3	80	22-16 (560)	8 (203)	3 (76)	7-1/2 (191)	13/32 (10)	2	5/8-11NC	4	6 (152)	5 (127)	6-1/4 (159)	1/16 (2)	9/16 (14)	2 (51)	6-1/8 (156)	62	28
4	100	25-13/16 (656)	8 (203)	4 (102)	9 (229)	13/32 (10)	2	5/8-11NC	8	7-1/2 (191)	6-3/16 (157)	6-1/4 (159)	1/16 (2)	11/16 (17)	2 (51)	7-1/8 (181)	77	35
6	150	35-7/16 (900)	10 (254)	6 (152)	11 (279)	7/16 (11)	2	3/4-10NC	8	9-1/2 (241)	8-1/2 (216)	7-3/8 (187)	1/16 (2)	5/8 (16)	2-1/4 (57)	10 (254)	110	50
8	200	46-1/8 (1172)	12 (305)	8 (203)	13-1/2 (343)	5/8 (16)	2	3/4-10NC	8	11-3/4 (298)	10-5/8 (270)	7-3/8 (187)	1/16 (2)	13/16 (21)	2-3/4 (70)	12-3/4 (324)	190	86
10	250	52-5/8 (1337)	16 (406)	10 (254)	16 (406)	1/2 (13)	4	7/8-9NC	12	14-1/4 (362)	12-3/4 (324)	7-3/8 (187)	1/8 (3)	15/16 (24)	2-3/4 (70)	16-1/8 (410)	260	118
12	300	62-1/8 (1578)	16 (406)	12 (305)	19 (483)	1/2 (13)	4	7/8-9NC	12	17 (432)	15 (381)	7-1/2 (191)	3/16 (5)	1 (25)	3 (76)	18-3/4 (476)	370	168
14	350	68-13/16 (1748)	20 (508)	13-1/4 (337)	21 (533)	7/16 (11)	4	1-8NC	12	18-3/4 (476)	16-1/4 (413)	7-3/4 (197)	3/16 (5)	15/16 (24)	3 (76)	19-7/8 (505)	441	200
16	400	78-13/16 (2002)	20 (508)	15-1/4 (387)	23-1/2 (597)	9/16 (14)	6	1-8NC	16	21-1/4 (540)	18-1/2 (470)	11-3/4 (298)	3/16 (5)	1-1/16 (27)	3-1/2 (89)	22-3/8 (568)	600	272
18	450	87-1/16 (2211)	20 (508)	17-1/4 (438)	25 (635)	5/8 (16)	6	1-1/8-7NC	16	22-3/4 (578)	21 (533)	11-3/5 (298)	3/16 (5)	1-1/16 (27)	3-1/2 (89)	24-3/8 (619)	714	324
20	500	95-15/16 (2437)	20 (508)	19-1/4 (489)	27-1/2 (699)	29/32 (23)	8	1-1/8-7NC	20	25 (635)	23 (584)	14 (356)	3/16 (5)	1-3/16 (30)	4-1/2 (114)	26-3/8 (670)	825	374
24	600	111 (2819)	20 (508)	23-1/4 (591)	32 (813)	13/16 (21)	8	1-1/4-7NC	20	29-1/2 (749)	27-1/4 (692)	14-1/8 (359)	3/16 (5)	1-5/16 (33)	4-1/2 (114)	31 (787)	1301	590

Reference Dimensions in (parentheses)

* For 14"-24" valves with rubber replaceable and poly replaceable seats, use the port I.D. dimensions show in the Flow Coefficients Table (See previous page)

** Figures C134R, C134S, F134R and F134S with Handwheel

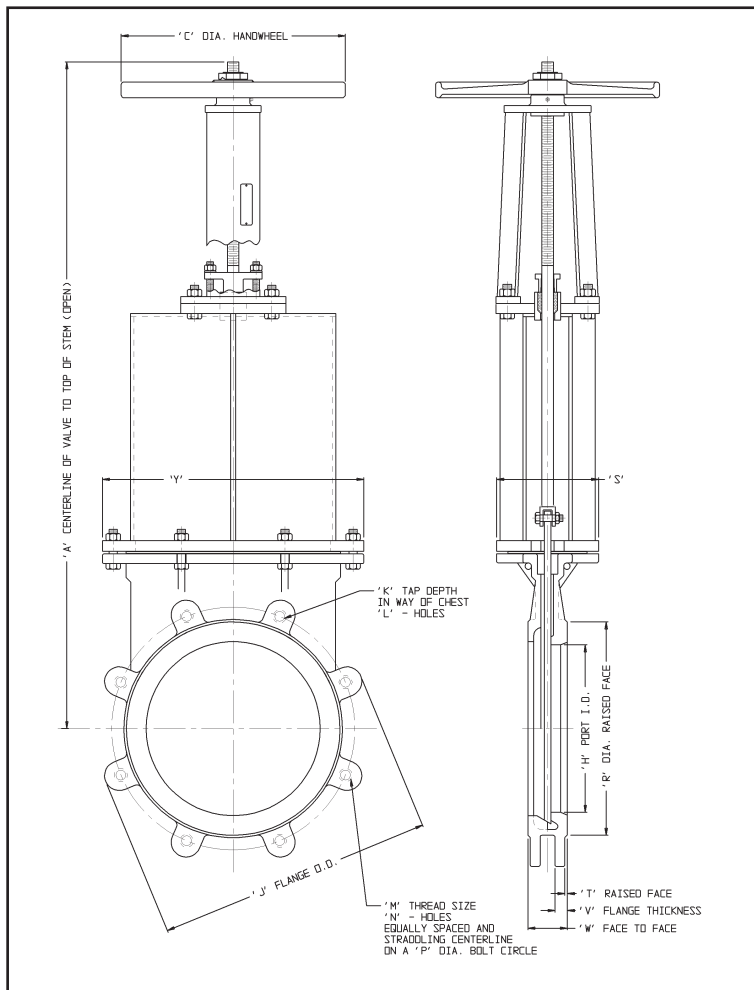

Available Options

- "D" Ring Seat
- Lever Operator
- Dual Seats
- Rubber Replaceable Seats
- Poly Replaceable Seats
- UHMW Replaceable Seats
- PTFE Replaceable Seats
- Hard Faced Replaceable Seats
- Hard Faced Integral SS Seats
- Hard Faced Gate Edge
- Hard Gate Material
- Nickel-TFE Coated Gate
- Epoxy Coating
- Thru Drilled Flanges
- Flush Ports
- Chest Buttons:
Required on valves without wiper packing
- Centerline Buttons
- Backing Ring
- Extra Wedges
- V-Port
- Cast Ni-Hard Deflection Cones:
Available 3" - 16"
- Fabricated Deflection Cones
- Locking Devices
- E-Z Spin Handwheel
- Live Loaded Packing
- Self-Supporting Yokes
- Alternate Flange Drilling
- Gate Wiper
- Back Seat
- Bevel Gear
- Chainwheels
- Cylinder Actuators
- Electric Actuators
- Ratchet
- Extended Stems
- Gate Support Strips
- Rod Boots

Pressure/Temperature Ratings

This table is the maximum pressure/temperature ratings for the metallic components only. When checking pressure/temperature ratings, check the temperature rating and chemical compatibility of the packing material, and if applicable, the resilient seat material. In a majority of knife gate valve designs, the temperature limit or the chemical compatibility of the seat and/or packing material determines the practical pressure/temperature limitations.

Low Pressure Operation

Metal seated knife gate valves are seat tested at 40 psid (2.8 bar) in the preferred flow direction. When pressure falls below the 40 psid (2.8 bar) test pressure, less force is pushing the gate into the seat, which may result in additional seat leakage. When improved low-pressure shutoff performance is required, optional chest buttons and/or centerline buttons should be specified.

Figure C/F134						
Pressure-Temperature Rating - psi						
Temp		304	304L	316	316L	317L
°F	°C					
150	66	150	133	150	133	150
200	93	133	114	141	113	135
250	121	126	108	133	107	128
300	149	120	102	124	101	121
350	177	115	98	119	97	116
400	204	110	93	114	93	112
450	232	107	90	110	90	108
500	260	103	87	106	87	105
600	316	97	82	101	83	100
700	371	94	80	97	80	96
800*	427*	89	77	93	77	92
900*	482*	87		92		
1000*	538*	83		90		
1100*	593*	64		76		
1200*	649*	41		46		
1300*	704*	28		29		
1400*	760*	18		18		
1500*	816*	11		10		

* F134R valves have external, non-wetted, carbon steel components. Standard F134R valves are limited to 700°F (371°C); however alternate F134R constructions are available to 1000°F (538°C)

NOTE: Each valve is identified by Size-Figure-Series-etc. The "How To Order" section explains the Valve Model Codes.

Materials of Construction

Parts	Materials	
	C134R	C134S
Body, Chest and Flanges	Stainless steel per customer specification.	Stainless steel per customer specification.
Bonnet	Same as body with carbon steel exterior parts	Same as body with carbon steel exterior parts
Gate	Same as body material	Same as body material
Yoke	Carbon steel	304 Stainless steel
Yoke Fasteners	Plated steel	Stainless steel
Stem	Same as body material	Same as body material
Stem Nut	Acid Resistant Bronze	Acid Resistant Bronze
Grease Fitting	Plated steel	Plated steel
Packing	PTFE/Graphite	PTFE/Graphite
Packing Follower	Carbon steel/Ductile Iron	316 Stainless Steel
Handwheel	Cast iron	Cast iron
Handwheel Retaining Nut	Malleable iron	Stainless steel
Tab Washer	Stainless steel	Stainless steel

Engineered Valves

For more information contact:

Engineered Valves

1110 Bankhead Avenue

Amory, MS 38821 USA

Phone: (800) 541-1849

(662) 256-7185

Fax: (662) 256-7932

Web site: www.engvalves.com

E-mail: engvalves.custserv@itt.com



Engineered for life

© 2007 ITT Corporation