



ITT

Fabri-Valve®

Drilling Fluid Valve (DFV)

DESIGNED SPECIFICALLY FOR TODAY'S DRILLING FLUID SYSTEMS

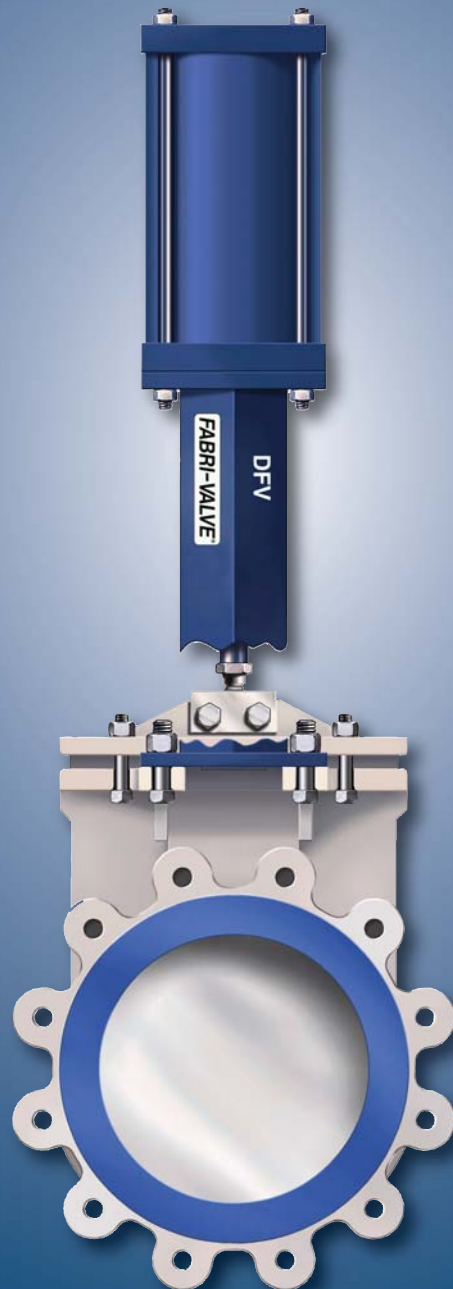

Engineered for life

Figure DFV

Revision 3

We're at the core of the drilling industry.

That core specifically is the demand for valves that stand up to harsh drilling fluid system requirements. Our Figure C45 DFV (Drilling Fluid Valve) met the demand for heavy duty replaceable seats - and with that we changed everything. Production expectations were raised. Drilling fluid systems functioned more efficiently and effectively.

And ITT has always been there. Developing a specially configured valve to improve operating efficiency, reliability and safety in today's drilling fluid systems. Designed and produced, hand-in-hand with input, influence, and expertise from some of the best engineers and operators in the drilling business, the Fabri-Valve DFV is a tried and true industry standard.

21st century choices.

Up until the 1980's, the only valves of choice for the drilling industry were metal seated knife gate valves and butterfly valves. Restricted flow and inherent leaking problems were par for the course. Adhesive O-rings, added for better sealing capacity, could not withstand the extremes of abrasion, temperature and chemical challenges that the drilling fluid presented. Special replaceable seats that extend the life of the drilling fluid system valves and an unobstructed flow design which reduces the potential for pump damage caused by back pressure and volume restrictions has made our DFV the industry standard.

The proven design of the DFV allows the drilling fluid system to function efficiently and effectively. ITT has been and will continue to be committed to meeting the needs of the drilling industry with the DFV.

Out of reach, yet close at hand.

Pneumatics. They're at the core of the DFV pneumatically-actuated control valve. Reliable and safe remote-location management, monitoring and regulating - all accomplished, if necessary, far from hard-to-access areas on the drilling fluid system.

Unlimited innovation for a limited space.

We know that dimensions are critical. We listened when you told us that. And that's why the DFV's port is a full port design offering 40% greater flow than a butterfly valve and replaces a butterfly valve with no dimensional changes. As a result of our unique DFV design, these valves can extend the life of centrifugal pumps by increasing flow and eliminating damage that can occur from back pressure. With increased flow and less potential for damage to the drilling system, you may find that your energy costs are decreased as well.

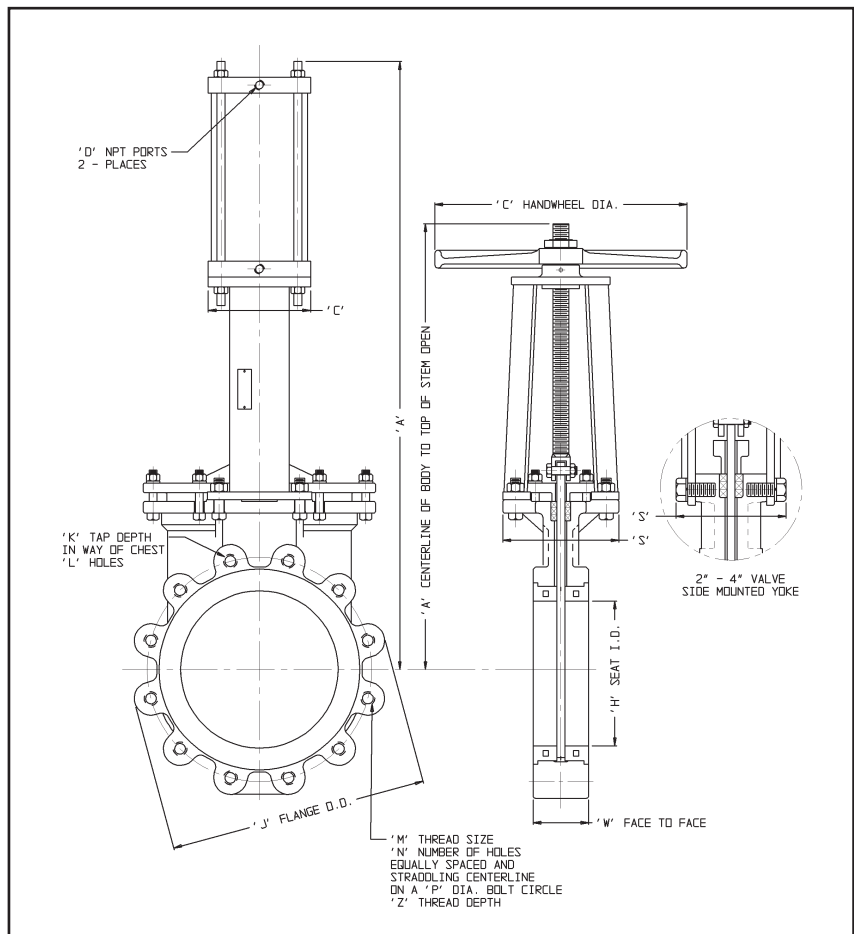

Dimensions

---- Valve Size		DIMENSION Inches (mm) C45 DFV with HANDWHEEL OR CYLINDER																	
Inches	DN	A			C			D		H	J	K	L	M	N	P	S	W	Z
		HW	2-1/2 CYL	3-1/4 CYL	HW	2-1/2 CYL	3-1/4 CYL	2-1/2 CYL	3-1/4 CYL										
2	50	14-13/16 (376)	18-3/8 (467)	16-7/8 (429)	8 (203)	3 (76)	4 (102)	3/8-18	1/4-18	2 (51)	6 (152)	1/2 (12)	2	5/8-11NC	4	4-3/4 (121)	4 (102)	1-7/8 (48)	9/16 (14)
		17-9/16 (446)	20-7/8 (530)	19-3/8 (492)	8 (203)	3 (76)	4 (102)	3/8-18	1/4-18	3 (76)	7-1/2 (191)	1/2 (12)	2	5/8-11NC	4	6 (152)	4 (102)	2 (51)	5/8 (16)
4	100	20-1/8 (511)	22-1/8 (562)	22-7/8 (581)	8 (203)	4 (76)	4-1/2 (114)	1/4-18	3/8-18	4 (102)	9 (229)	1/2 (12)	2	5/8-11NC	8	7-1/2 (191)	4 (102)	2 (51)	5/8 (16)
		25-11/16 (652)	28-7/8 (733)	29-1/4 (743)	10 (254)	4-1/2 (114)	6-1/2 (165)	3/8-18	3/8-18	6 (152)	11 (279)	9/16 (14)	2	3/4-10NC	8	9-1/2 (241)	7-3/8 (187)	2-1/4 (57)	3/4 (19)
8	200	33-27/32 (860)	35-13/16 (910)	36-5/16 (922)	12 (305)	6-1/2 (165)	8-5/8 (219)	3/8-18	3/8-18	8 (203)	13-1/2 (343)	5/8 (16)	2	3/4-10NC	8	11-3/4 (298)	7-3/8 (187)	2-3/4 (70)	1 (25)
		38-25/32 (985)	41-7/16 (1053)	42-3/16 (1072)	16 (406)	8-5/8 (219)	10-7/8 (276)	3/8-18	1/2-14	10 (254)	16 (406)	5/8 (16)	4	7/8-9NC	12	14-1/4 (362)	7-3/8 (187)	2-3/4 (70)	1 (25)
12	300	44-19/16 (1133)	48 (1219)	48-3/4 (1238)	16 (406)	8-5/8 (219)	10-7/8 (276)	3/8-18	1/2-14	12 (305)	19 (483)	5/8 (16)	4	7/8-9NC	12	17 (432)	7-1/2 (191)	3 (76)	1 (25)
		50 (1270)	54-1/16 (1373)	55-3/16 (1402)	20 (508)	12-3/4 (324)	14-3/4 (375)	1/2-14	3/4-14	12 (305)	21 (533)	21/32 (17)	4	1-8NC	12	18-3/4 (476)	7-3/4 (197)	3 (76)	1 (25)
16	400	57-1/16 (1449)	61-1/16 (1551)	62-3/16 (1580)	20 (508)	12-3/4 (324)	14-3/4 (375)	1/2-14	3/4-14	14-1/4 (362)	23-1/2 (597)	25/32 (20)	6	1-8NC	16	21-1/4 (540)	11-1/4 (286)	3-1/2 (89)	1-1/4 (32)
		63-9/16 (1614)	66-1/2 (1689)	67-5/8 (1718)	20 (508)	12-3/4 (324)	14-3/4 (375)	1/2-14	3/4-14	16-1/4 (413)	25 (635)	3/4 (19)	6	1-1/8-7NC	16	22-3/4 (578)	11-1/4 (286)	3-1/2 (89)	1-3/8 (35)
20	500	69-7/16 (1764)	72-15/16 (1853)	73-7/16 (1865)	20 (508)	14-3/4 (375)	17 (432)	3/4-14	3/4-14	18 (457)	27-1/2 (699)	1-1/8 (29)	8	1-1/8-7NC	20	25 (635)	14 (356)	4-1/2 (114)	1-1/2 (38)
		80-5/8 (2048)	84-11/16 (2151)	86-5/8 (2200)	20 (508)	17 (432)	19 (483)	3/4-14	3/4-14	22 (559)	32 (813)	1-1/16 (27)	8	1-1/4-7NC	20	29-1/2 (749)	14-1/8 (359)	4-1/2 (114)	1-1/2 (38)

Reference Dimensions in (parentheses)

Valves for the life of the job.

You want these valves to last until the job is done. The DFV uses easily replaceable seats to provide bubble tight shut-off from 0-150 psi (10.3 bar). These replaceable seats are retained by the mating flange, which reduces maintenance time. To deliver a positive seal around the gate, DFV valves are designed with PTFE Graphite braided packing that keeps its sealing surface memory. The DFV also utilizes a first row of Kevlar packing to act as a wiper – protecting the packing from abrasive drilling fluid.

Features & Benefits

- Maximum temperature 250°F (121°C).
- Long lasting replaceable seats
- Reduces pump damage caused by back pressure and volume restrictions
- Flow capacity - 40% greater than conventional butterfly valves
- Zero leakage of fluid at 0-150 psi (10.3 bar)
- Positive shut-off at 0-150 psi (10.3 bar) in both directions with dual seats
- Replaces butterfly valve with no dimensional changes
- Seat flush ports are standard
- Ease of automation
- Safe remote operation away from hard-to-access areas

We have the valve you need.

Every job has specific valve requirements. That's why we manufacture the Fabri-Valve DFV in a variety of materials of construction. We offer handwheel, gear operator, double acting air cylinder, spring return cylinder, hydraulic cylinder or electric operator configurations. Ask us. Our breakthrough innovation and valve advancement experts are ready to give you the valve solution for your success.

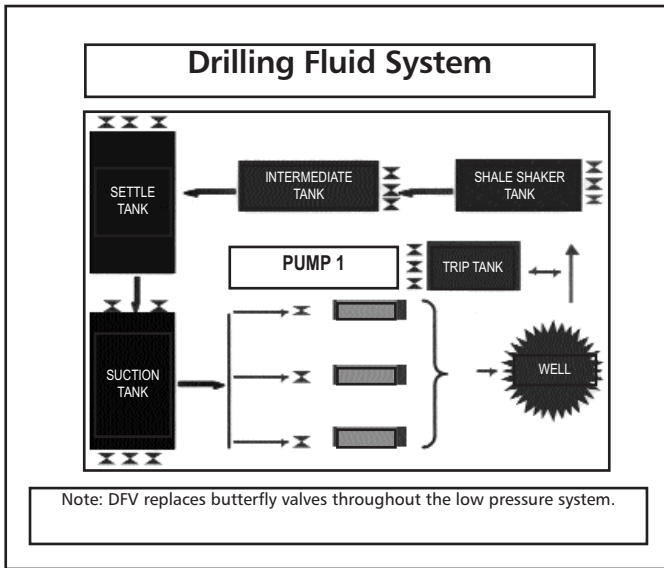

Available Options

- Hard Gate Material
- Thru Drilled Flanges
- Flush Ports (STD)
- Locking Devices
- Live Loaded Packing
- Self-Supporting Yokes
- Single Replaceable Seat (Uni-directional Service)
- "Energized Packing" with Viton® Core

Engineered Valves

For more information contact:

Engineered Valves

1110 Bankhead Avenue

Amory, MS 38821 USA

Phone: (800) 541-1849

(662) 256-7185

Fax: (662) 256-7932

Web site: www.engvalves.com

E-mail: engvalves.custserv@itt.com



Engineered for life

© 2007 ITT Corporation