

Skotch® Trifecta T4000C Series Gas

Revision 1

For larger igniters and smaller main burners, the patented Skotch Trifecta T4000C series cast-body valve system is a safe, cost-effective, reliable alternative to the multiple valves and manifolds found in fuel gas systems.

Used in applications where double block and vent is required, the T4000C combines the functions of two independent block valves with a normally open vent valve in a single, compact unit making it ideal for boilers, furnaces, and process heating equipment firing natural gas, propane, or other fuel gas. The unique design includes three ports: inlet, outlet, and vent. The cast steel body contains two valve plugs – an inlet and outlet block. The chamber between is open to vent through the hollow inlet stem.

Flow to close inlet and outlet blocks are sized for full flow to minimize pressure loss; increasing inlet pressure forces the blocks tighter on their seats. Soft seals with over-travel and metal-to-metal back up seats assure positive ANSI/FCI 70-2 Class VI closure. Proof-of closure (POC) switch is standard.

Advantages of using the T4000C valve system vs. conventional multiple valve and manifold setups include:

- Compact for easier installation
- Less maintenance and lower cost of ownership
- Available Factory Mutual (FM) approved configurations (fail closed only)
- No out-of-sequence operation
- Can be installed in any orientation

Because the T4000C valves operate using a single actuator, problems such as out-of-sequence operation, jamming, and maladjustment of linkage drive systems are eliminated.



T4100C (1")

Shown with optional Proof of Open switch and external limit switch option



T4150C (1.5")

Flow Capacity for the T4100C

The following chart depicts the relationship between flow (SCFH) and pressure drop (PSI) for the T4100C Skotch Trifecta valve system. Data is given at various inlet pressures (PSIG). Follow known flow up the chart until you intersect the known operating pressure. Where the two lines intersect, look to the left for the calculated pressure drop.

T4100C example: With 10,000 SCFH flow operating at 15 PSI the calculated pressure drop will be 3.3 PSI.

Calculations are based on natural gas at 0.65 specific gravity, at 60° F.

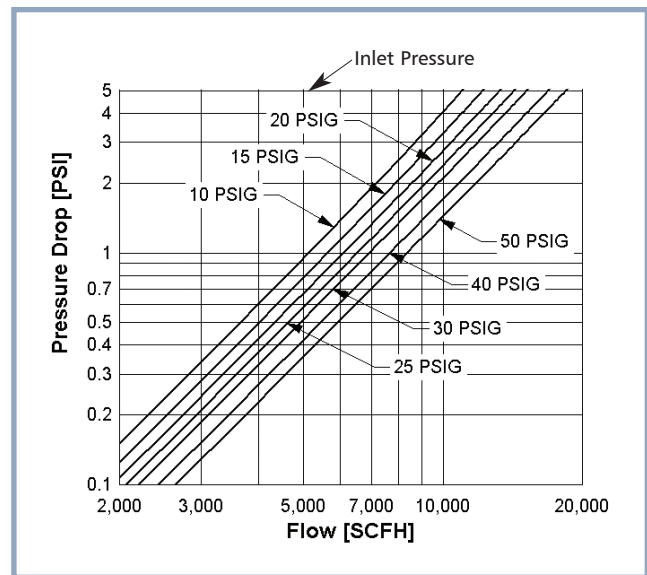

Specifications for the T4100C

Design Pressure and Temperature:

Max operating pressure: 50 PSIG
 Temperature rating: -20°F to 150°F

Shutoff Classification:

All ports soft seated with metal to metal backup
 New valve: meets or exceeds ANSI/FCI 70-2 Class VI
 Durability: meets or exceeds FM 7400 standard for Safety Shutoff Valves (SSOV)

Cv Rating: 14

Inlet/Outlet Size: 1" Sch. 40 (Sch. 80 optional)

End Connections:

Inlet/Outlet: Sch. 40 or 80 Spigot; Butt Weld; ANSI Class 150 Raised-Face Flange; Male NPT in Sch. 80; Socketweld

Vent: ANSI B2.1 FNPT

Pneumatic Supply:

Clean, dry air at 60 to 120 PSIG

Flow Direction: Left to Right or Right to Left. Field reversible

Orientation: May be installed in any position.

Construction Materials:

Body: ANSI B16.34 compliant; cast carbon steel per ASTM A216 Gr. WCB

Flanges: ASTM A479 Type 304, ASTM A108 1018
 Trim: ASTM Type 300 series stainless steels
 Seals: Buna-N standard; Consult factory for Viton options

Actuation:

Electropneumatic
 T4105C- Fail Last Position
 T4106C- Fail Closed (Safe), FM Approved
 T4107C- Fail Closed, non-FM Approved

Solenoid Supply Voltages:

110 or 220 VAC, 50/60 Hz
 12, 24, 48 and 125 VDC

Switch Rating:

Internal Switches - 7 Amps @ 120 VAC
 External Switches - 10 Amps @ 125 VAC

Switch/Solenoid Electrical Ratings:

Location Classification
 Standard: Nema 1, 3, 4, 13
 Optional: Nema 7, 9 (Class 1 Div 2 Gr. B, C, D) (External switches only)

Ingress Protection

Standard: Nema 4

Optional: Nema 4X (External switches only)

Weight:

Approximately 35 lbs depending on options selected

Dimensional Specifications for the T4100C

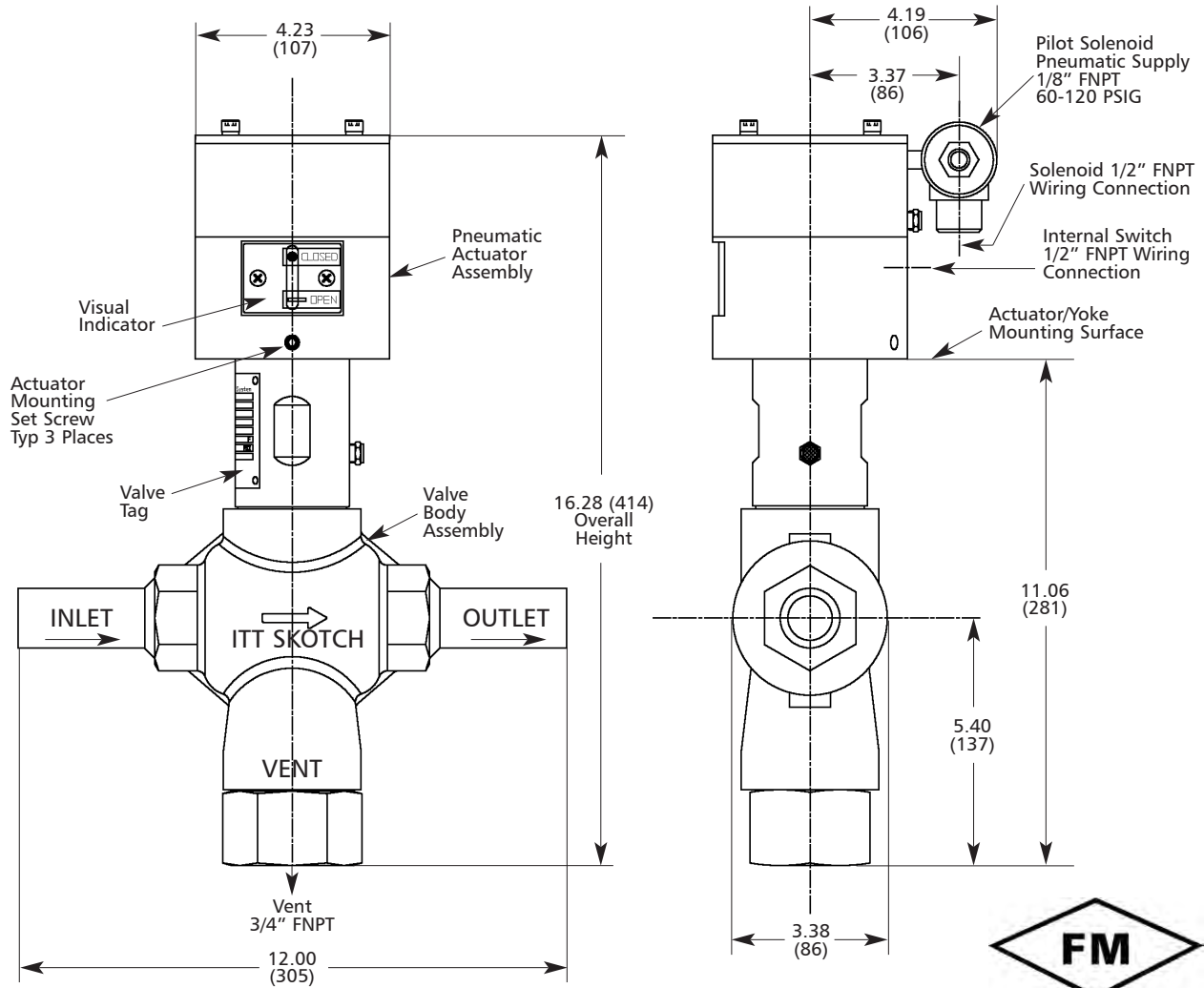

T4000C systems are covered under U.S. Patent No. 5,165,443 and other foreign patents. Dimensions are inches (mm)

FM Approved for valves which fail in the closed position and incorporate appropriate options.

Externally Mounted Limit Switch Option

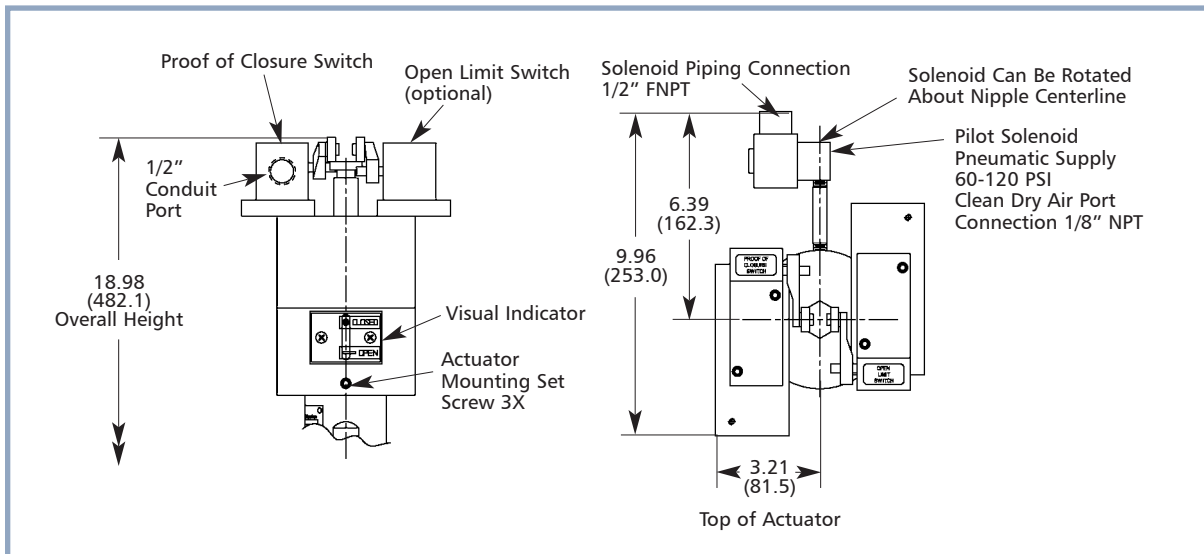

Flow Capacity for the T4150C and T4200C

The following chart depicts the relationship between flow (SCFH) and pressure drop (PSI) for the T4150C and T4200C Trifecta valve systems. Data is given at various inlet pressures (PSIG). Follow known flow up the chart until you intersect the known operating pressure. Where the two lines intersect, look to the left for the calculated pressure drop.

T4150C example: With 20,000 SCFH flow operating at 15 PSI the calculated pressure drop will be 1.2 PSI.

Calculations are based on natural gas at 0.65 specific gravity, at 60° F.

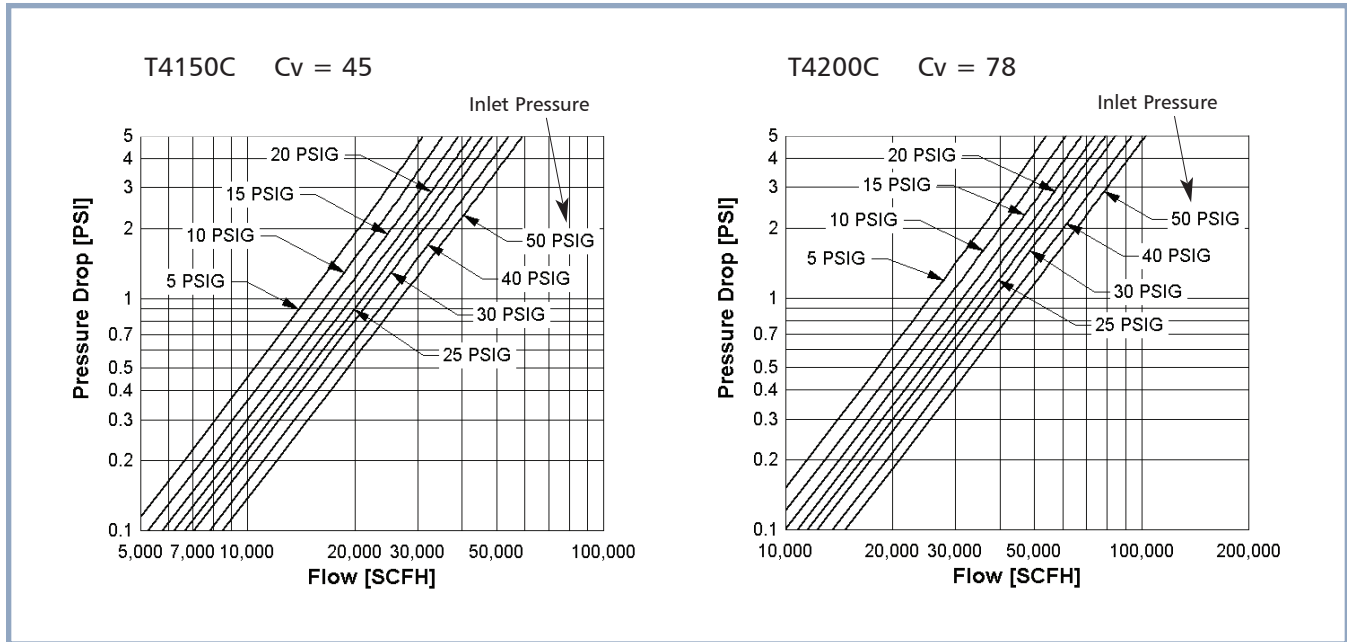

Sizes & Weights:

Series	Line Size	Vent Size	Weight*
T4150C	1.5"	3/4"	111 lbs
T4200C	2.0"	1"	162 lbs

* Approximate depending on options selected

End Connections:

Inlet/Outlet: Sch. 40 or 80 Spigot; Butt Weld;
ANSI Class 150 Raised-Face Flange;
Male NPT in Sch. 80; Socketweld

Vent: ANSI B2.1 FNPT

Design Pressure and Temperature:

Max. operating pressure: 60 PSIG
Operating temperature range: -20°F to 180°F

Ambient Temperature Rating: 180°F Max.
(Consult factory for higher requirements)

Shutoff Classification:

All ports soft seated with metal to metal backup
New valve: meets or exceeds ANSI/FCI 70-2 Class VI
Durability: meets or exceeds FM 7400 standard for Safety Shutoff Valves (SSOV)

Construction Materials:

Body: ANSI B16.34 compliant; cast carbon steel per ASTM A216 Gr. WCB

Flanges: ASTM A479 Type 304, ASTM A108 1018

Trim: ASTM Type 300 series stainless steels

Seals: Buna-N standard; Consult factory for Viton options

Actuation:

T4xx5 - Fail in Last Position

T4xx6 - Fail Closed (safe), FM Approved

T4xx7 - Fail Closed, non-FM Approved

Pneumatic Supply: 60 to 120 PSIG Clean, Dry Air

Solenoid Supply Voltages:

110 VAC, 220 VAC 50/60 Hz

12, 24, 48, 125 VDC

Switch / Solenoid Electrical Ratings:

Location Classification

Standard: Nema 1, 3, 4, 13

Optional: Nema 7, 9 (Class 1 Div. 2 Gr. B,C,D)

Ingress Protection:

Standard: Nema 4

Optional: Nema 4X

Switch Rating: 10 Amps at 125 VAC

Dimensional Specifications for the T4150C and T4200C

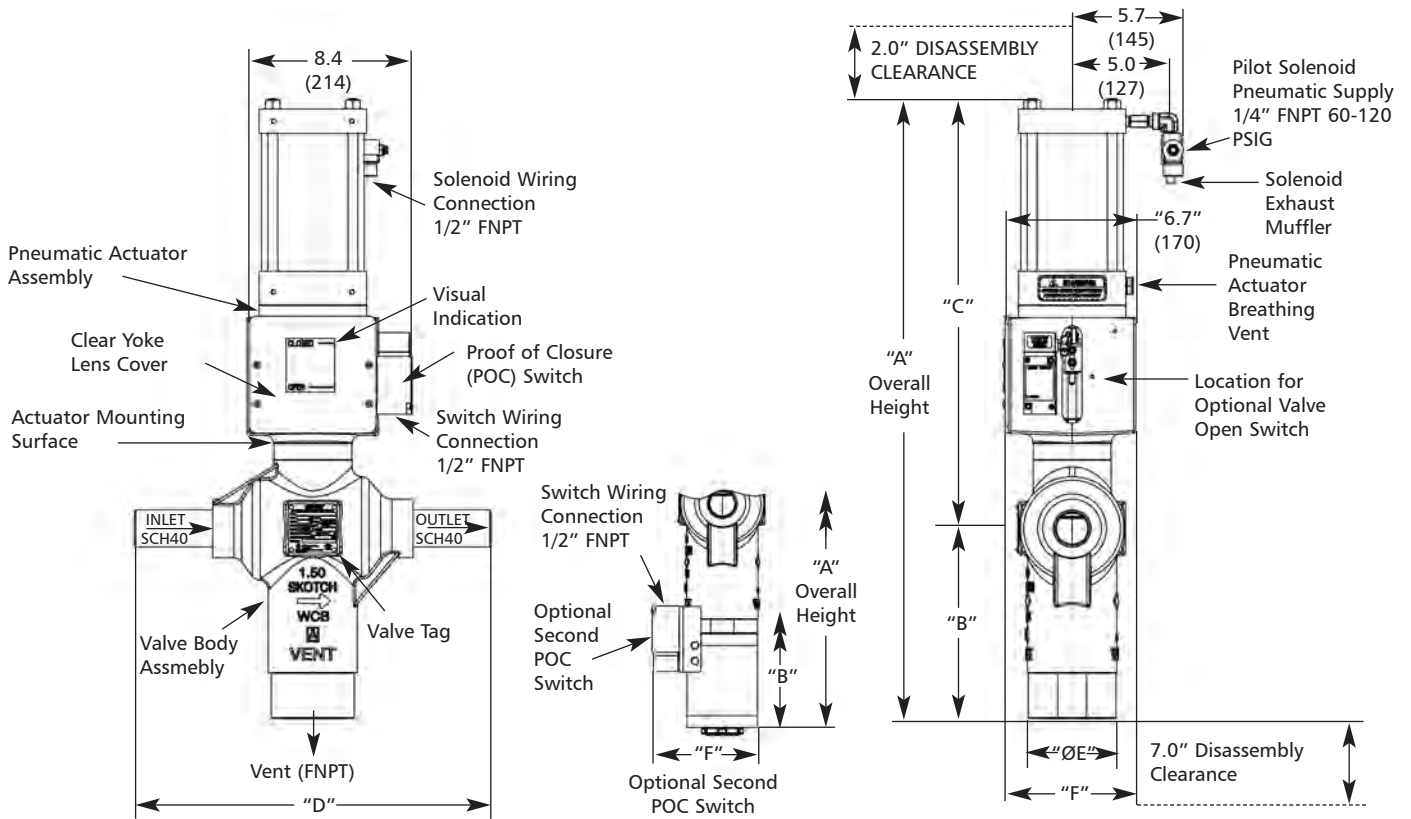

Model	Pipe Run Size	Vent Connection	Dim "A"	Dim "B"	Dim "C"	Dim "D"	Dim "E" Ø	Dim "F"
T4150C Base	1.5"	0.75" FNPT	31.8 (808)	9.8 (249)	22.0 (559)	18.3 (465)	4.6 (117)	5.6 (142)
T4150C w/ 2nd POC	1.5"	0.75" FNPT	36.9 (937)	14.9 (378)	22.0 (559)	18.3 (465)	4.6 (117)	7.2 (183)
T4200C Base	2.0"	1.0" FNPT	33.5 (851)	10.1 (257)	23.4 (594)	21.8 (554)	5.4 (137)	7.1 (180)
T4200C w/ 2nd POC	2.0"	1.0" FNPT	39.0 (991)	15.5 (394)	23.4 (594)	21.8 (554)	5.4 (137)	8.3 (211)

*Dimensions are inches (mm)

T4000C systems are covered under U.S. Patent No. 5,165,443 and other foreign patents.



FM Approved for valves which fail in the closed position and incorporate appropriate options.

Principles of Operation

Opening

1. Energizing the actuator extends its output shaft, forcing the valve's outlet stem down to open the outlet block and compress the Actuator spring.
2. As the system opens, a soft vent seal on the bottom of the outlet plug contacts a flat surface on the inside of the inlet plug stem. The spring energized vent seal is compressed until a metal to metal backup seat is made. At this point the outlet is open and the vent is fully closed. (Figure 2)
3. The valve continues to travel through vent closure, driving the inlet plug out of its seat and compressing the inlet spring.
4. When the inlet plug's soft seal clears the seat ring, both blocks are open, the vent is closed, and gas moves from the inlet port to the outlet port. The valve stops at full open. (Figure 3)

Closing

1. For valve shutoff, the actuator is deenergized, causing the valve's two independent return springs to close the block valves. (Inlet block spring and actuator return spring)
2. First, the inlet block closes, making first a soft seal, halting the flow of gas, and then over traveling to make a metal to metal backup seal. Next, the vent opens, relieving down-stream pressure. Finally, the outlet block closes, making a soft seat and then over traveling to make a metal to metal backup seat, isolating the vent from the burner.
3. With the inlet and outlet blocks closed and the vent open, any potential leakage past the inlet valve escapes to vent through the hollow inlet stem. This positively ensures no leakage into the burner. (Figure 1)

Figure 1 - Closed

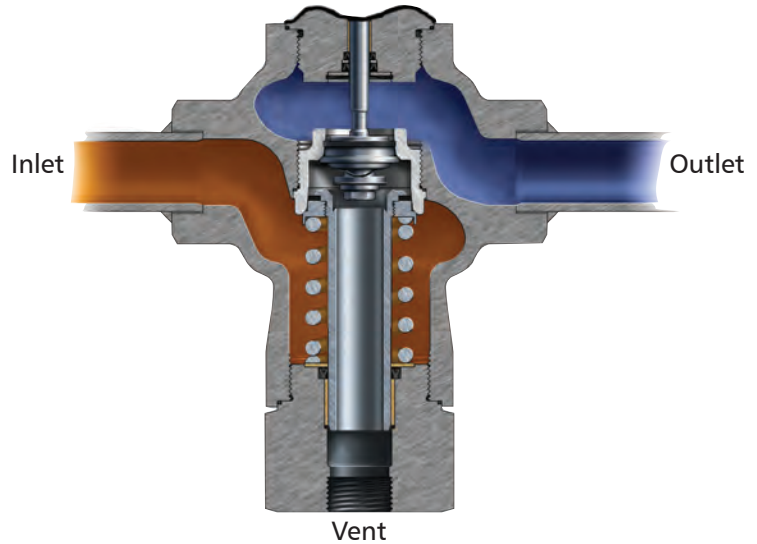

Figure 2 - Intermediate

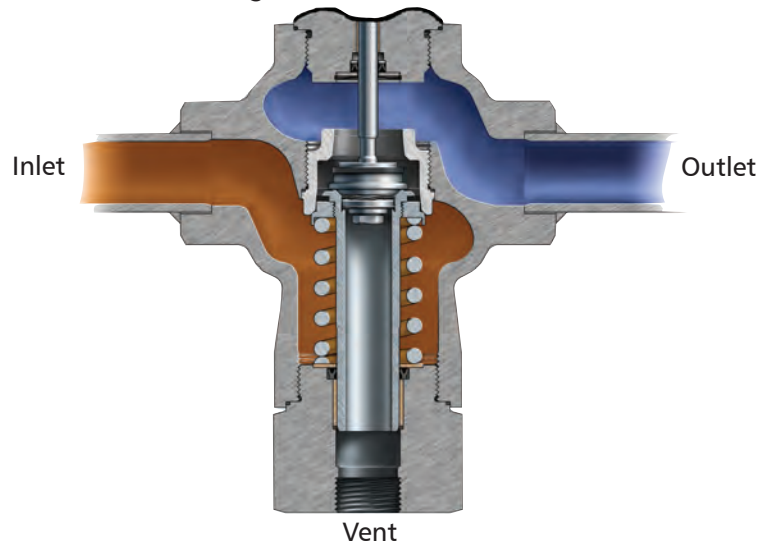

Figure 3 - Open

