

The patented Skotch Trifecta T4000F series fabricated body valve system is a safe, cost-effective, reliable alternative to multiple valves and manifolds found in fuel gas systems. Used in applications where double block and vent is required, the T4000F combines the function of two independent block valves with a normally open vent valve in a single, compact unit making it ideal for boilers, furnaces and process heating equipment firing natural gas, propane, and other fuel gas.

A single actuator mechanically opens the two block valves and closes the vent, assuring that the valves operate in sequence. Use of independent spring-to-close block valves ensures that obstructing one valve does not prevent the other from closing. The Trifecta valve system has no exposed linkage that

can be damaged and requires no adjustments for proper operation.

Because Skotch Trifecta valve systems are custom built for each application, we are able to modify our standard offerings to suit our customer needs. Installation flexibility is increased since the outlet and vent ports can be rotated at 90° increments, and the valves can be mounted in any orientation. The valve system is completely self-contained and all necessary accessories are provided, including position indication switches and junction box.

Skotch Trifecta gas valve systems have been proven as a superior alternative to multiple valves systems by decreasing installation space, time, and money while increasing safety and reliability.



## Features & Benefits:

- Provides all necessary block and vent functions in a single integral unit
- Use of a single actuator ensures reliable in-sequence operation. Block valve closure springs are independent for reliable closure
- Fabricated design allows for installation flexibility
- Compact design saves space
- All three valves provide ANSI/FCI 70-2 Class VI shutoff with over-travel and metal-to-metal back up seats
- Complies with NFPA and IRI's recommended good design practices for vent port size
- Outlet and vent ports can be rotated at 90° increments, and the valves can be mounted in any orientation
- Built in test port to allow leakage testing while valve is in line
- No external linkage; rugged enclosure protects all components
- Designed for in-line maintenance

# Operating Sequence for the T4000F

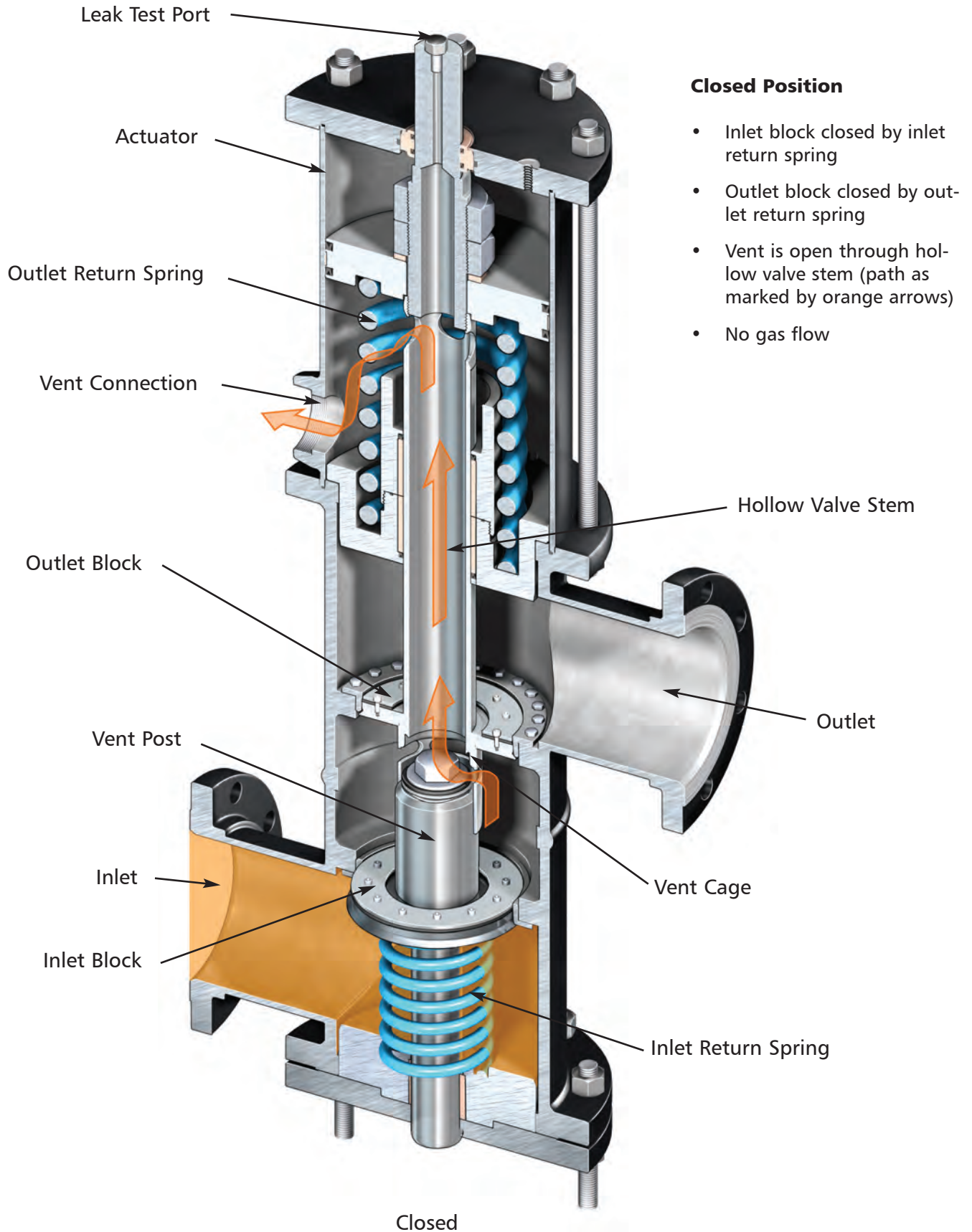

# Operating Sequence for the T4000F

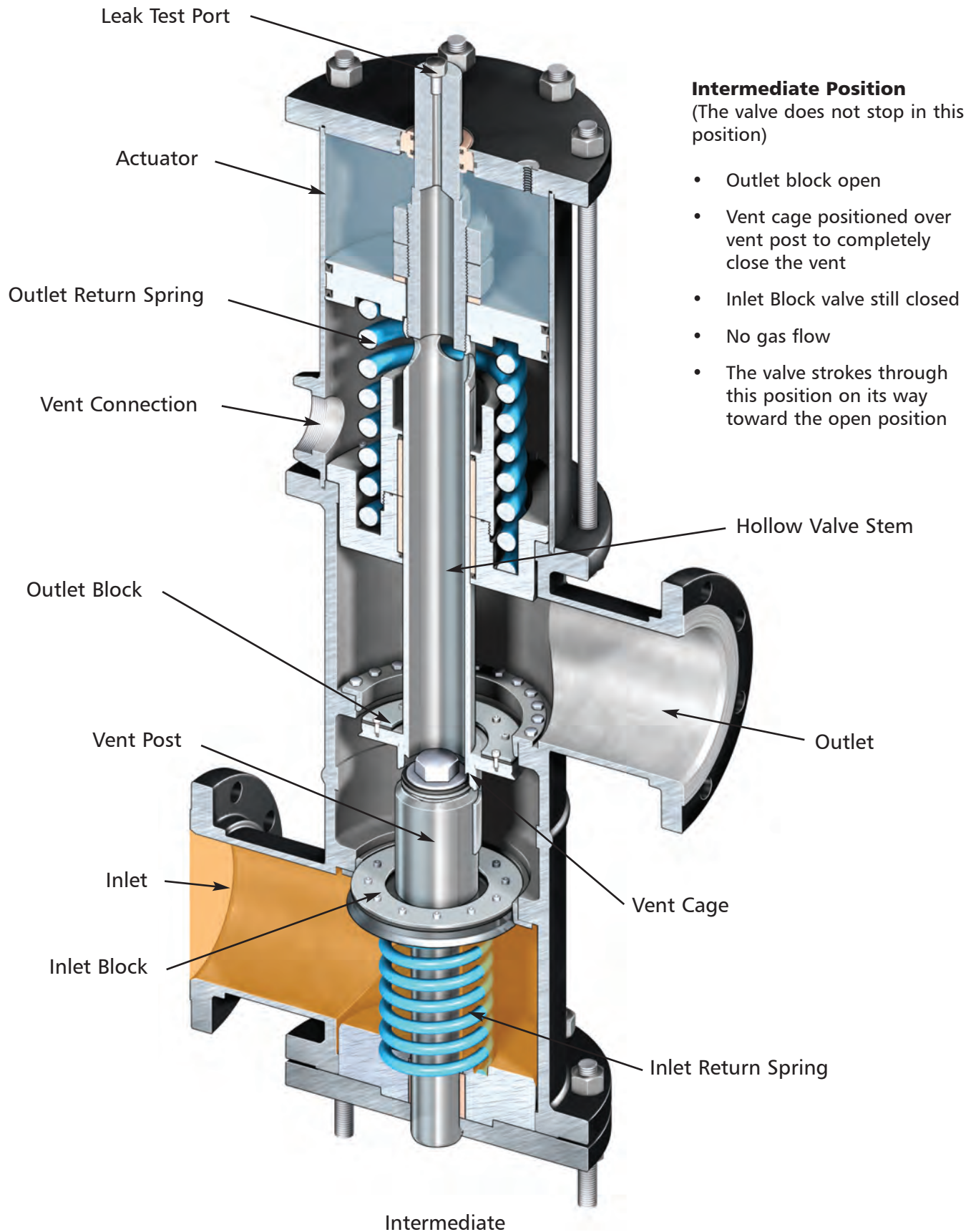

Intermediate

# Operating Sequence for the T4000F

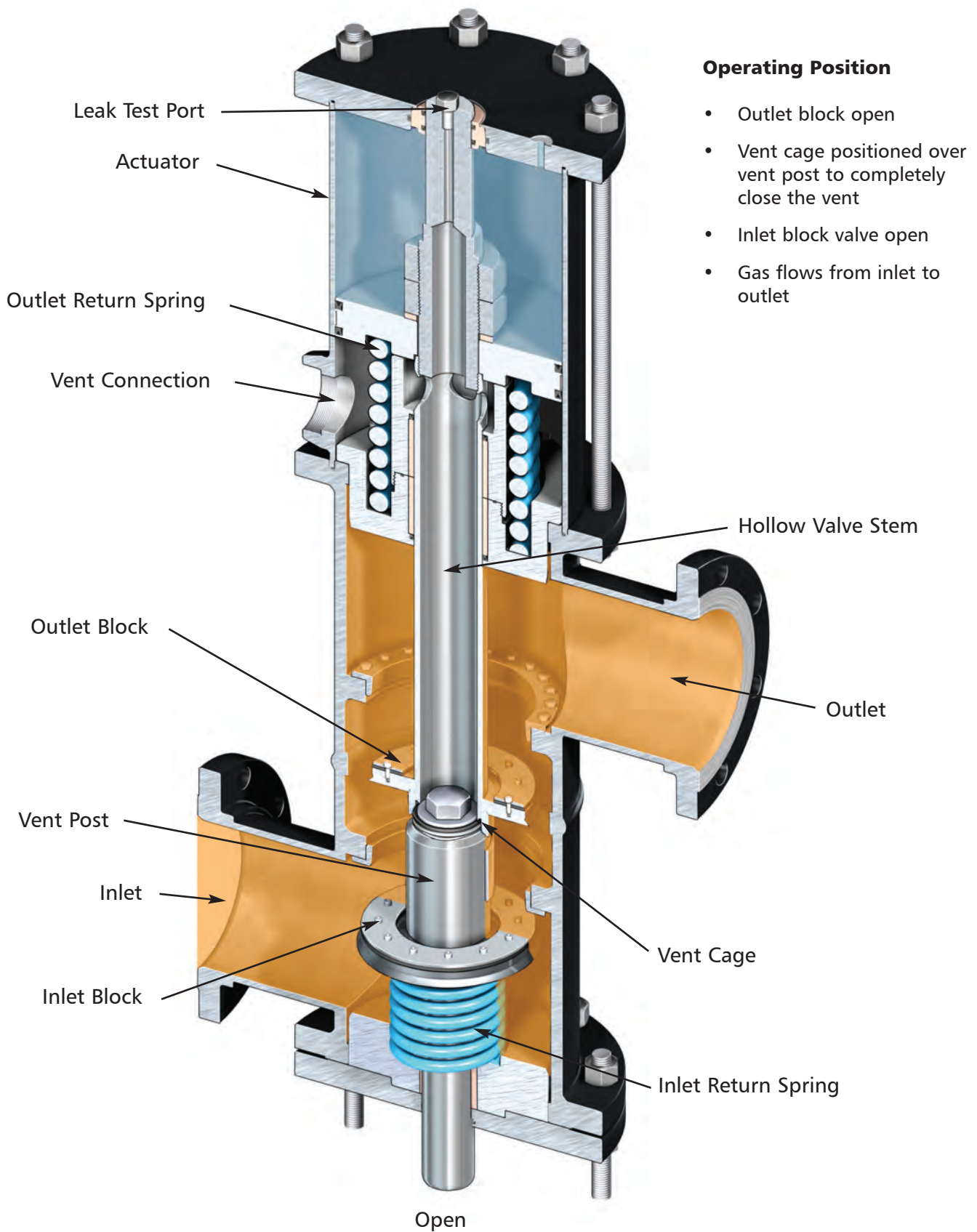

# Specifying Configurations 2" through 6"

## T4000F Body Configurations

The two-inch (T4200F) through six-inch (T4600F) valve systems are fabricated design. As a result, outlet and vent connections as well as the junction box can be located at any point in 90° in relation to the

inlet connection. Listed here are standard orientations from which to choose.

**Note:** Vent and junction box should not be in the same location.

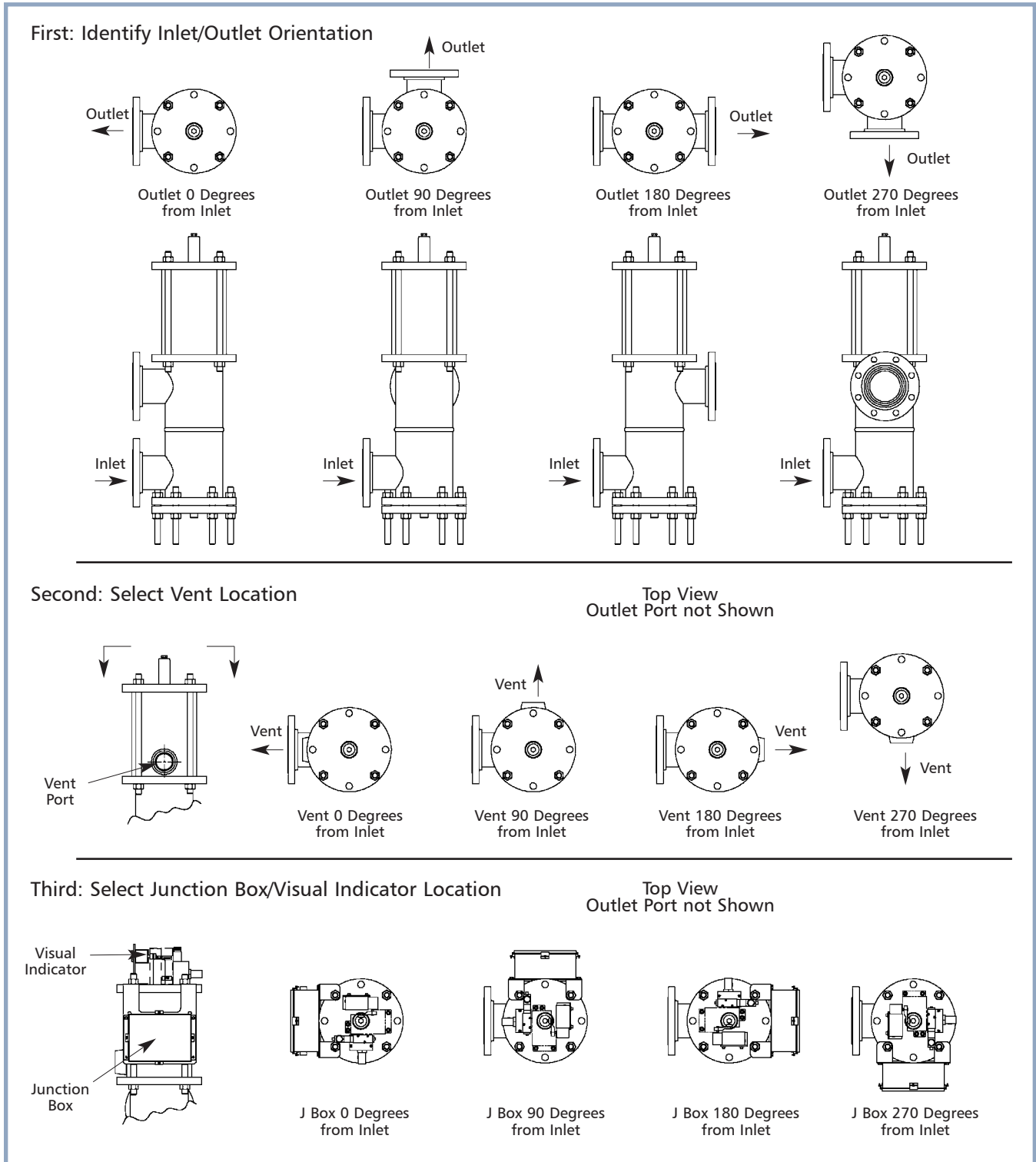

# Dimensional Information

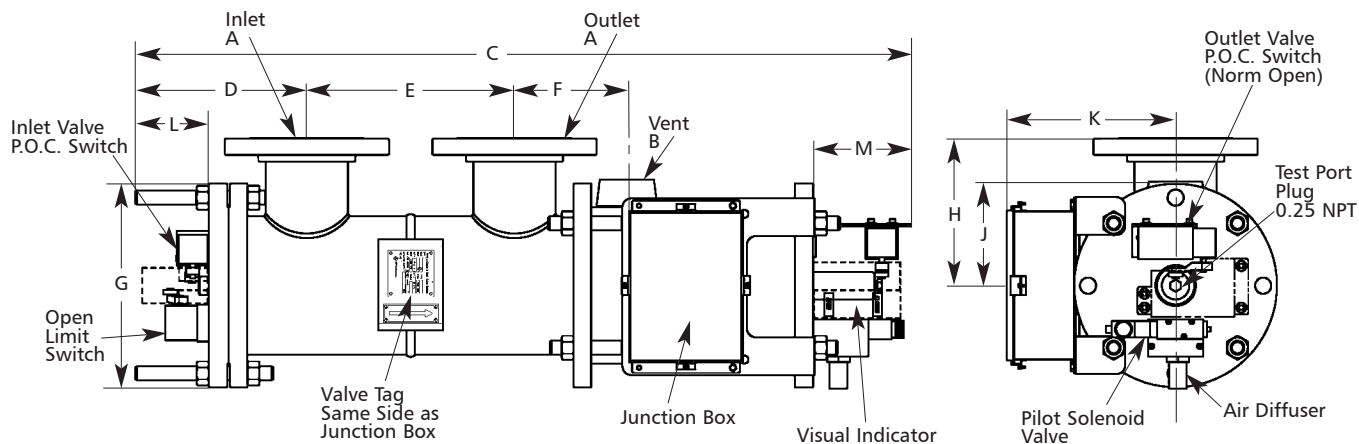

T4000F Systems are covered under U.S. Patent No. 4,798,223 and other foreign patents.

## General Dimensions (Inches)

Valve Series	Line Size A	Vent Size B	C	D	E	F	G	H	J	K	L	M
T4200F	2.00 R.F. Flange	1.00 FNPT	36.81	9.11	7.50	5.02	9.00	6.00	3.93	9.42	4.50	5.30
T4300F	3.00 R.F. Flange	1.25 FNPT	40.79	8.69	10.12	5.53	11.00	7.50	5.54	9.63	4.00	5.30
T4400F	4.00 R.F. Flange	2.00 FNPT	40.98	9.31	11.27	6.10	11.00	7.93	5.63	9.63	4.00	5.30
T4600F	6.00 R.F. Flange	2.50 FNPT	54.38	10.06	15.00	8.13	13.50	11.00	7.38	11.42	4.25	5.88

## General Dimensions (Metric)

Valve Series	C	D	E	F	G	H	J	K	L	M
T4200F	935.0	231.4	190.5	127.5	228.6	152.4	99.8	239.3	114.3	134.6
T4300F	1036.1	220.7	257.0	140.5	279.4	190.5	140.7	244.6	101.6	134.6
T4400F	1040.9	236.5	286.3	154.9	279.4	201.4	143.0	244.6	101.6	134.6
T4600F	1381.3	255.5	381.0	206.5	342.9	279.4	187.5	290.1	108.0	149.4

# Specifications for the T4000F

### Design Pressure and Temperature:

Max. operating pressure – 50 PSIG  
 Max operating temperature – 180°F

### Sizes & Weights:

Series	Line Size	Vent size	Weight*
T4200F	2"	1"	137 lbs
T4300F	3"	1 ¼"	240 lbs
T4400F	4"	2"	265 lbs
T4600F	6"	2 ½"	515 lbs

\*Approximate depending on options selected

### End Connections:

Inlet/Outlet: ANSI B16.5 Cl 150 Raised Face Flange  
 Vent: ANSI B2.1 Female NPT, Sch 40 or 80 Spigot, Butt weld  
 (CL 150 Raised face flange optional)

### Actuation:

T4x05 – Fail in last position  
 T4x06 – Fail closed, FM approved  
 T4x07 – Fail closed, non-FM approved  
 Pneumatic Supply: 60 to 120 PSIG clean, dry air  
 (70 PSIG minimum for T4600F only)

### Shutoff Classification:

All ports soft seated with metal to metal backup  
 New valve: meets or exceeds ANSI/FCI 70-2 Class VI  
 Durability: meets or exceeds FM 7400 standard for Safety Shutoff Valves (SSOV)

### Ambient Temperature Rating:

Standard: 140°F (FM approved)  
 Optional: 180°F (non-FM approved)

### Electrical Rating:

Standard – Nema 1, 3, 4, 13  
 Optional – Nema 7, 9 (Class 1 Div 2 Gr B, C, D)

**Switch Rating:** 10 Amps at 125 VAC

### Pilot Solenoid Voltages:

110 VAC, 220 VAC 50/60 Hz  
 12, 24, 48, 125 VDC

### Cv Ratings:

T4200F – 80  
 T4300F – 167  
 T4400F – 245  
 T4600F – 430



FM Approved for valves which fail in the closed position and incorporate appropriate options.

# Flow Capacity Charts

## 2" through 6"

The following charts depict the relationship between flow (SCFH) and pressure drop (PSI) for 2 inch through 6 inch Trifecta valves. Data is given at various inlet pressures (PSIG). Follow known flow up the chart until you intersect the known operating pressure. Where the two lines intersect, look to the left for the pressure drop.

Example: 3" valve system with 100,000 SCFH natural gas flow operating at 15 PSIG inlet pressure the pressure drop will be 2.3 PSI. Selecting a 4" valve system with the same conditions will result in a pressure drop of 1.0 PSI.

Estimated pressure drops are reported for the entire Trifecta double block and vent system.

Figures can be used to compare relative performance of the various valve sizes. Please note that calculations do not take into effect external piping elements, such as reducers, tees, and elbows. When comparing this data with that of other manufacturers, please ensure any comparison figure estimates the performance over two block valves closely-coupled and not just a single valve.

For other process conditions, calculations may be performed using the Cv values noted in valve specification data, or contacting the factory. Calculations are based on natural gas at 0.65 specific gravity, 60 degrees F.

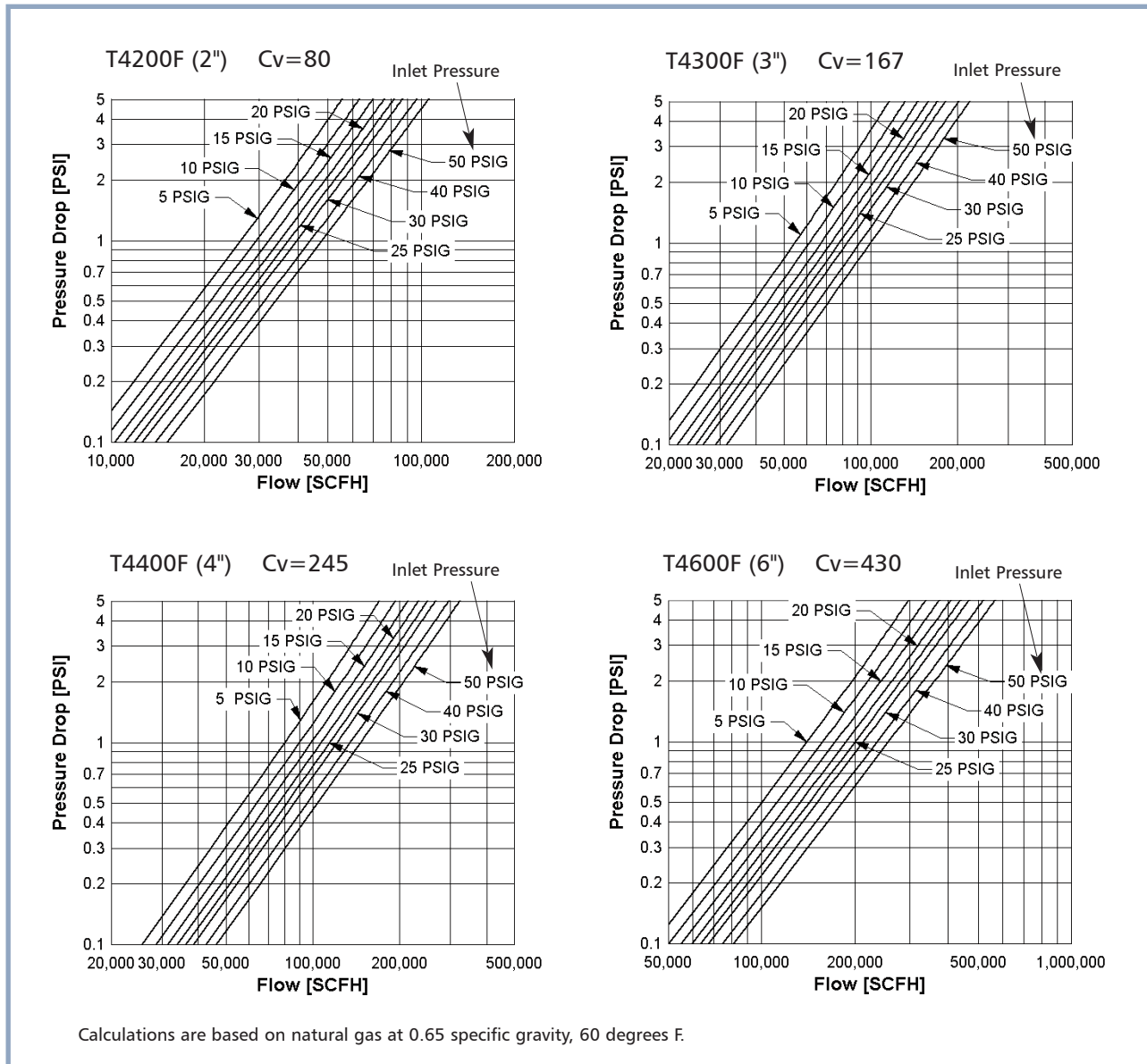

# Principles of Operation

## Opening

1. With the block valves closed and the vent open, gas enters the inlet port and is blocked by two flow-to-close plugs (the inlet and outlet block). To positively prevent fuel leakage into an idle burner, the chamber between is vented to atmosphere through the hollow outlet valve stem. (Figure 1)

2. Pneumatic pressure at the top of the actuator cylinder moves the piston downward, compressing the outlet return spring and forcing the outlet block open. The cage slides down over the post until the machined surfaces inside the cage come in contact first with a spring-energized soft seal, and then with a metal back-up seat, closing the vent. (Figure 2)

3. With the vent closed, the system continues to stroke, pushing the inlet block open, so that gas begins to flow. A travel stop halts valve movement after full stroke is achieved. (Figure 3)

## Closing

1. To close the valve and open the vent, pilot air is exhausted from the actuator. Return springs drive the inlet and outlet valves toward their seats. (Figure 3)

2. As the inlet valve enters its seat ring, gas flow is isolated. The inlet block moves through its over-travel until contact is made with the back-up seat to fully close the inlet valve. (Figure 2)

3. As the outlet valve continues moving toward its seat, the cage separates from the post, opening the vent. The outlet block enters the seat ring, isolating the vent from downstream piping. When the outlet block contacts the metal back-up seat, the system is fully closed. (Figure 1)

Figure 1

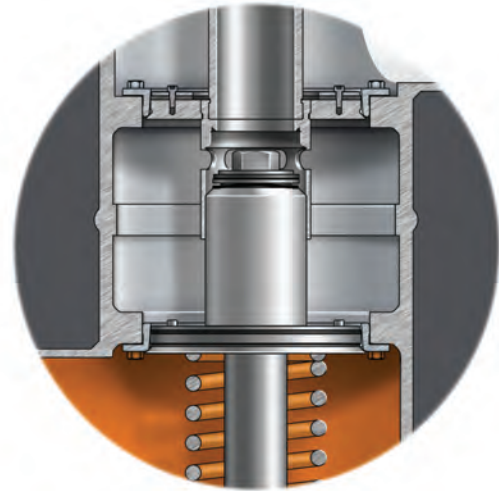

Figure 2

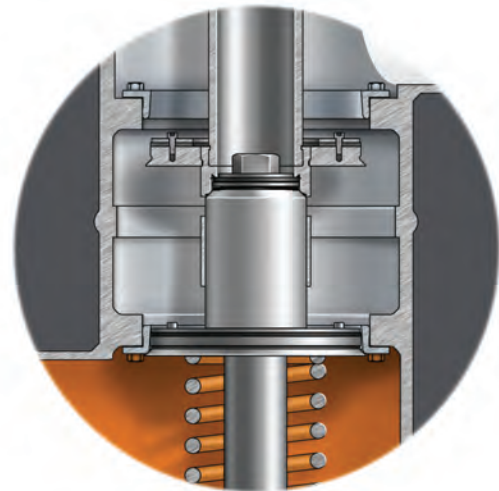

Figure 3

