



F39 Slide Gate Valve



ITT

ENGINEERED FOR LIFE

F39 Slide Gate Valve

The Fabri-Valve Figure F39 slide gate valve is designed for shut off and throttling in difficult abrasive and/or high solids slurry service. The standard round port configuration is used for on/off service and the optional diamond port configuration is used for throttling. Available with a handwheel or automated, the Figure F39 has the unique ability to operate in a static column of solid particles and powders. The opening in the slide gate merely moves a disc of material laterally then returns it when the slide gate is reversed. Consult factory for shut off capability with standard and optional seats.

All Figure 39 slide gate valves with handwheels include a provision for a locking device. Consult factory for details.

Specifications

Size Range	1.5" – 96"
Pressure Rating	
1.5" – 24":	150 (10.3 bar) CWP (cold working pressure)
25" – 48" :	Available in 50 (3.5 bar), 100 (6.9 bar) and 150 (10.3) CWP
Above 48":	Manufactured to customer specification
	Consult factory for higher pressure designs.
Temperature Rating	
1.5" – 48":	500°F (260°C)
	Service temperatures above 400°F (204°C) require high temperature fasteners. Specify service temperature on paperwork. Consult factory for sizes larger than 48" (DN1200) and for service temperatures up to 2000°F(1093°C).
Flange Drilling	ANSI 125/150

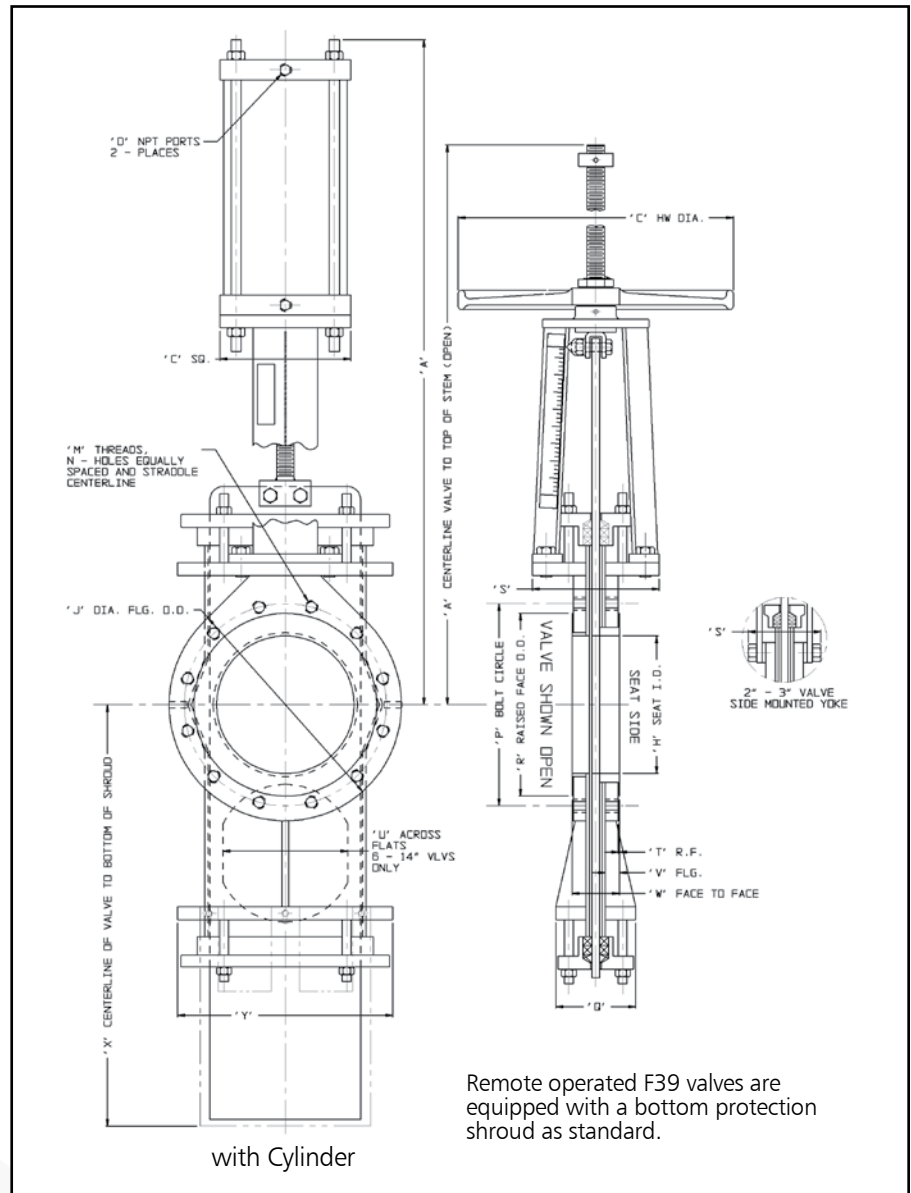
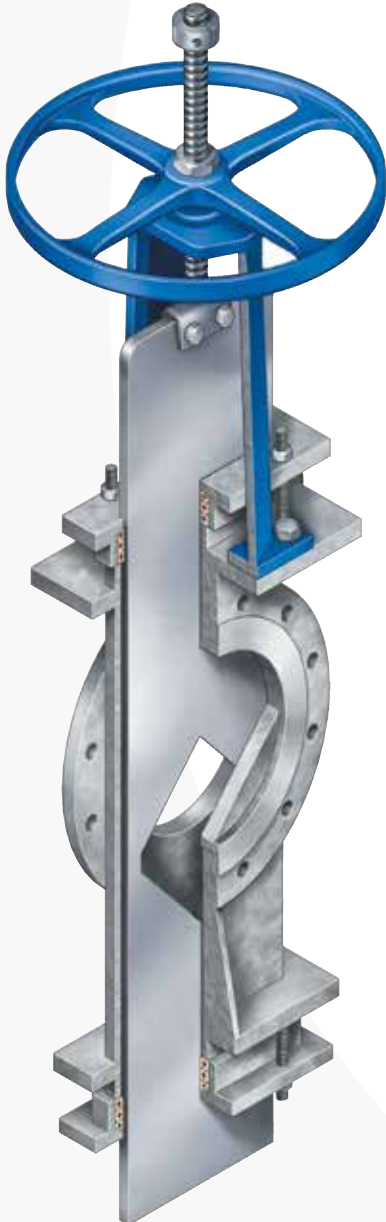

Remote operated F39 valves are equipped with a bottom protection shroud as standard.

Testing

Every Fabri-Valve Figure F39 valve is tested prior to shipment. Testing includes a body shell test and a cycling test to insure proper functioning of moving parts. Valves with a resilient seat are also seat tested. Additional testing is also available. Please let us know your requirements.

Shell test: Hydro test at 1.5 times the rated CWP — zero allowable leakage

Seat test: Resilient seat — Hydro test at 15 psi (1 bar) and rated CWP — allowable leakage as follows:

Single "D" ring, or single replaceable resilient seat (excluding PTFE)

All sizes zero leakage

Single replaceable PTFE seat

All sizes consult factory

Dual seats – all configurations

All sizes consult factory

Materials of Construction

Part	Materials	
	F39R	F39S
Wetted Body and Chest Components	Stainless steel type 304, 316 or 317L	Stainless steel type 304, 316 or 317L
External Flanges and Stiffeners	Carbon steel flanges	Same as wetted components
Seat	Same as wetted components	Same as wetted components
Gate	Same material as body finished to 63 RMS	Same material as body finished to 63 RMS
Yoke	Carbon steel	304 stainless steel
Yoke Bolting	Plated steel	Stainless steel
Packing	Acrylic/PTFE/silicone	Acrylic/PTFE/silicone
Packing Follower	Ductile iron/Carbon steel	Stainless steel
Follower Bolting	Plated steel	Stainless steel
Stem	304 stainless steel	304 stainless steel
Stem Nut	Acid resistant bronze	Acid resistant bronze
Lubrication Fitting	Plated steel	Plated steel
Handwheel	Cast iron	Cast iron
Handwheel Retaining Nut	Malleable iron	Stainless steel
Tab Washer	Stainless steel	Stainless steel
Travel Stop	Plated steel	Stainless steel

Dimensions

Valve Size		DIMENSION Inches (mm) F39 with HANDWHEEL OR CYLINDER																			Weight*				
Inches	DN	A			C			D		H	J	M	N	P	Q	R	S	T	U	V	W	X	Y	lb	kg
2	50	HW	2-1/2 CYL	3-1/4 CYL	HW	2-1/2 CYL	3-1/4 CYL	2-1/2 CYL	3-1/4 CYL	2 (51)	6 (152)	5/8-11NC	4	4-3/4 (121)	4 (102)	3-5/8 (92)	3-11/16 (94)	1/16 (2)	N/A	9/16 (14)	1-7/8 (48)	9-3/8 (238)	6-1/2 (165)	40	18
		16 (406)	19 (483)	17-1/2 (445)	8 (203)	3 (76)	4 (102)	3/8-18	1/4-18																
3	80	HW	2-1/2 CYL	3-1/4 CYL	HW	2-1/2 CYL	3-1/4 CYL	2-1/2 CYL	3-1/4 CYL	3 (76)	7-1/2 (191)	5/8-11NC	4	6 (152)	4 (102)	5 (127)	3-11/16 (94)	1/16 (2)	N/A	9/16 (14)	2 (51)	11-7/8 (302)	7-5/8 (194)	45	20
		18-3/4 (476)	21-3/4 (552)	20-1/4 (514)	8 (203)	3 (76)	4 (102)	3/8-18	1/4-18																
4	100	HW	3-1/4 CYL	4 CYL	HW	3-1/4 CYL	4 CYL	3-1/4 CYL	4 CYL	4 (102)	9 (229)	5/8-11NC	8	7-1/2 (191)	4 (102)	6-3/16 (157)	7-3/8 (187)	1/16 (2)	N/A	9/16 (14)	2 (51)	13-1/2 (343)	9 (229)	64	29
		24-3/8 (619)	25-1/16 (637)	25-13/16 (656)	10 (254)	4 (102)	4-1/2 (114)	1/4-18	3/8-18																
6	150	HW	4 CYL	6 CYL	HW	4 CYL	6 CYL	4 CYL	6 CYL	6 (152)	11 (279)	3/4-10NC	8	9-1/2 (241)	4-1/8 (105)	8-1/2 (216)	7-3/8 (187)	1/16 (2)	5-1/4 (133)	11/16 (17)	2-1/4 (57)	19-3/8 (492)	10-3/8 (264)	94	43
		28-1/2 (724)	31-5/16 (795)	31-11/16 (805)	10 (254)	4-1/2 (114)	6-1/2 (165)	3/8-18	3/8-18																
8	200	HW	6 CYL	8 CYL	HW	6 CYL	8 CYL	6 CYL	8 CYL	8 (203)	13-1/2 (343)	3/4-10NC	8	11-3/4 (298)	4-1/4 (108)	10-5/8 (270)	7-3/8 (187)	1/16 (2)	7-1/4 (184)	13/16 (21)	2-3/4 (70)	25 (635)	12-1/2 (318)	174	79
		34-3/4 (883)	36-11/16 (932)	37-3/16 (945)	12 (305)	6-1/2 (165)	8-5/8 (219)	3/8-18	3/8-18																
10	250	HW	8 CYL	10 CYL	HW	8 CYL	10 CYL	8 CYL	10 CYL	10 (254)	16 (406)	7/8-9NC	12	14-1/4 (362)	4-5/8 (117)	12-3/4 (324)	7-1/2 (191)	1/16 (2)	8-3/4 (222)	13/16 (21)	2-3/4 (70)	30-3/16 (767)	13-7/8 (352)	245	111
		41-11/16 (1059)	42-3/4 (1086)	43-1/2 (1105)	16 (406)	8-5/8 (219)	10-7/8 (276)	3/8-18	1/2-14																
12	300	HW	8 CYL	10 CYL	HW	8 CYL	10 CYL	8 CYL	10 CYL	12 (305)	19 (483)	7/8-9NC	12	17 (432)	4-7/8 (124)	15 (381)	7-3/4 (197)	1/8 (3)	11-1/4 (286)	7/8 (22)	3 (76)	34-7/8 (886)	15-7/8 (403)	326	148
		45 (1143)	48-1/8 (1222)	48-7/8 (1241)	16 (406)	8-5/8 (219)	10-7/8 (276)	3/8-18	1/2-14																
14	350	HW	12 CYL	14 CYL	HW	12 CYL	14 CYL	12 CYL	14 CYL	13-5/8 (346)	21 (533)	1-8NC	12	18-3/4 (476)	7 (178)	16-1/4 (413)	11-1/8 (283)	1/8 (3)	13-1/4 (337)	7/8 (22)	3 (76)	40-15/16 (1040)	19-7/8 (505)	444	201
		53-1/16 (1348)	54-3/4 (1391)	55-7/8 (1419)	20 (508)	12-3/4 (324)	14-3/4 (375)	1/2-14	3/4-14																
16	400	HW	12 CYL	14 CYL	HW	12 CYL	14 CYL	12 CYL	14 CYL	15-1/4 (387)	23-1/2 (597)	1-8NC	16	21-1/4 (540)	7 (178)	18-1/2 (470)	11-1/4 (286)	1/8 (3)	N/A	1 (25)	3-1/2 (89)	44-13/16 (1138)	22 (559)	620	281
		57-15/16 (1472)	60-7/8 (1546)	62 (1575)	20 (508)	12-3/4 (324)	14-3/4 (375)	1/2-14	3/4-14																
18	450	HW	12 CYL	14 CYL	HW	12 CYL	14 CYL	12 CYL	14 CYL	17-1/4 (438)	25 (635)	1-1/8-7NC	16	22-3/4 (578)	10 (254)	21 (533)	11-1/4 (286)	1/8 (3)	N/A	1 (25)	3-1/2 (89)	50-9/16 (1284)	23-7/8 (606)	Consult Factory	
		65 (1651)	66-1/8 (1680)	67-1/4 (1708)	20 (508)	12-3/4 (324)	14-3/4 (375)	1/2-14	3/4-14																
20	500	HW	14 CYL	16 CYL	HW	14 CYL	16 CYL	14 CYL	16 CYL	19-1/4 (489)	27-1/2 (699)	1-1/8-7NC	20	25 (635)	10 (254)	23 (584)	14 (356)	1/8 (3)	N/A	1-3/8 (35)	4-1/2 (114)	55-11/16 (1414)	26-1/2 (673)	Consult Factory	
		72-1/8 (1857)	74 (1880)	74-1/2 (1892)	20 (508)	14-3/4 (375)	17 (432)	3/4-14	3/4-14																
24	600	HW	16 CYL	18 CYL	HW	16 CYL	18 CYL	16 CYL	18 CYL	23-1/4 (591)	32 (813)	1-1/4-7NC	20	29-1/2 (749)	11 (279)	27-1/4 (692)	14 (356)	1/8 (3)	N/A	1-3/8 (35)	4-1/2 (114)	64-9/16 (1640)	31 (787)	Consult Factory	
		81-3/8 (2067)	86 (2184)	87-15/16 (2234)	20 (508)	17 (432)	19 (483)	3/4-14	3/4-14																

* Valve with Handwheel

Flow Coefficients

The Cv values below represent U.S. gallons per minute 60°F water through a 100% open valve at a pressure drop of 1 psi. The metric equivalent, Kv, is the flow of water at +16°C through the valve in cubic meters per hour at a pressure drop of 1 kg/cm². To convert Cv to Kv, multiply the Cv by 0.8569.

Figure F39 Slide Gate Valves							
C _v Ratings, Port Diameter and Area							
		V-Port			O-Port		
Valve Size		C _v	Port I.D. Inches	Port Area Sq. In.	C _v	Port I.D. Inches	Port Area Sq. In.
In.	DN						
2	50	115	1.4	2.0	288	2.00	3.1
3	75	215	2.1	4.4	648	3.00	7.1
4	100	465	2.9	8.4	1,152	4.00	12.6
6	150	1,050	4.3	18.5	2,592	6.00	28.3
8	200	2,050	5.7	32.5	4,608	8.00	50.3
10	250	3,350	7.1	50.4	7,208	10.00	78.5
12	300	4,950	8.5	72.2	10,400	12.00	113.1
14	350	8,513	9.7	94.1	13,400	13.63	145.8
16	400	10,700	10.8	116.6	16,750	15.25	182.6
18	450	13,750	12.2	148.8	21,450	17.25	233.7
20	500	17,030	13.6	184.9	26,700	19.25	291.0
24	600	24,825	16.5	272.2	38,900	23.25	424.6

Available Options

- "D" Ring Seat
- Dual Seats
- Poly Replaceable Seats
- UHMW Replaceable Seats
- PTFE Replaceable Seats
- Rubber Replaceable Seats
- Hard Faced Replaceable Seats
- Hard Faced Integral SS Seats
- Hard Faced Gate Edge
- Hard Gate Material
- Nickel -TFE Coated Gate
- Epoxy Coating
- Thru Drilled Flanges
- Flush Ports
- Chest Buttons: Not available 2"-6"
- Backing Ring
- V-Port
- Locking Devices
- Live Loaded Packing
- Self-Supporting Yokes
- Bevel Gear
- Chainwheels
- Cylinder Actuators
- Electric Actuators
- Ratchet
- Extended Stems
- Gate Support Strips
- Rod Boots
- E-Z Spin Handwheel



ENGINEERED FOR LIFE

ITT Engineered Valves
33 Centerville Road
Lancaster, PA 17603, USA
Tel: +1 (717) 509-2200

Cam-Line, Cam-Tite, Dia-Flo,
EnviZion, Pure-Flo, Skotch

ITT Engineered Valves
1110 Bankhead Avenue
Amory, MS 38821, USA
Tel: +1 (662) 256-7185

Fabri-Valve

Pressure/ Temperature Ratings

The Cv values below represent U.S. gallons per minute 60°F water through a 100% open valve at a pressure drop of 1 psi. The metric equivalent, Kv, is the flow of water at +16°C through the valve in cubic meters per hour at a pressure drop of 1 kg/cm². To convert Cv to Kv, multiply the Cv by 0.8569.

Figure F39 Slide Gate Valve								
Pressure-Temperature Rating - psi								
Temp		304	304L	316	316L	317L	A 36	A516Gr70
°F	°C							
150	66	150	133	150	133	150	150	150
200	93	133	114	141	113	135	137	150
250	121	126	108	133	107	128	135	150
300	149	120	102	124	101	121	133	150
350	177	115	98	119	97	116	131	150
400	204	110	93	114	93	112	128	150
450	232	107	90	110	90	108	125	150
500	260	103	87	106	87	105	121	150
600	316	97	82	101	83	100	111	150
700	371	94	80	97	80	96	108	142
800*	427*	89	77	93	77	92		103
900*	482*	87		92				57
1000*	538*	83		90				21
1100*	593*	78		88				
1200*	649*	49		59				
1300*	704*	30		33				
1400*	760*	18		18				
1500*	816*	11		10				

* "R" Series valves have alloy steel wetted parts and a carbon steel exterior. Standard "R" Series valves are limited to 700°F (371°C); however alternate "R" Series constructions are available to 1000°F (538°C)

NOTE: Each valve is identified by Size-Figure-Series-etc. The "How To Order" section explains the Valve Model Codes.

ITT Industries Ltd.
Weycroft Avenue,
Millwey Rise Industrial Estate
Axminster, EX13 5HU, United Kingdom
Tel: +44 1297-639100
EnviZion, Pure-Flo