

CLOSE COUPLED

FURNISHED

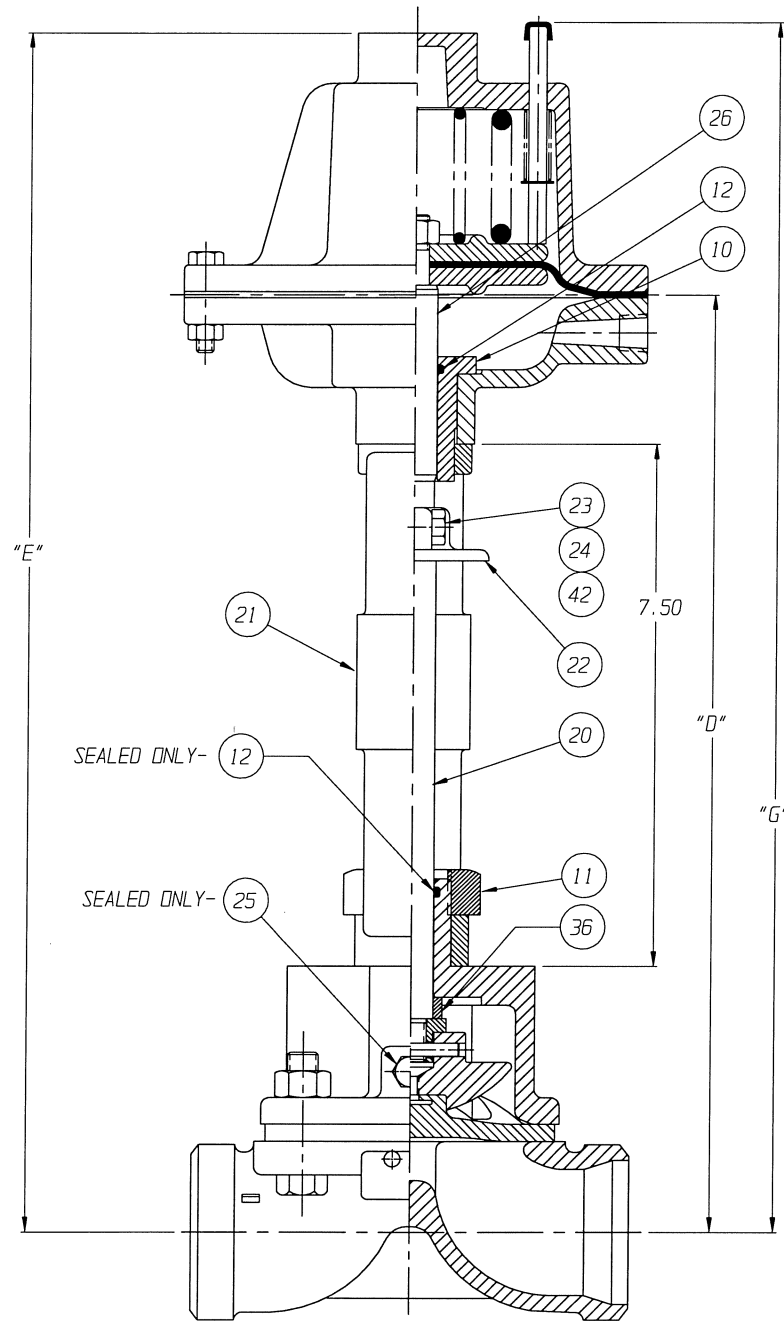

YOKE MOUNTED  
IRON BONNET

FURNISHED

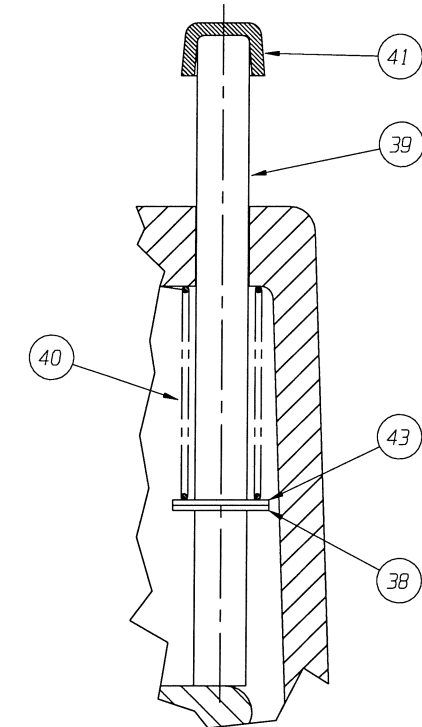

DETAIL  
POSITION INDICATOR  
(OPTIONAL)

ENGRD VALVES ORDER: - ITEM: -  
 SHEET - OF -  
 FIGURE NO.: -  
 CUSTOMER: -  
 CUSTOMER P.O.: -  
 ISSUED BY: - CERTIFIED BY: -

THIRD ANGLE PROJECTION		DATE	BY	VALVE ASSEMBLY WEIR 00.50 THRU 02.00 #12 REVERSE ACTUATOR WITH BUTTWELDED ENDS (PIPE)	<b>ITT Industries</b> Engineered Valves Lancaster, PA USA
	DWN	01-25-02	BLM		
	CHKD	01-25-02	STD		
	APVD	01-25-02	STD		
ECN# 6601	UNLESS OTHERWISE SPECIFIED, ALL DIMENSIONS ARE IN INCHES			CS D	004188 SHEET 1 OF 2
					REV B

VALVE SIZE	'A'	'B'	'C'	'D'	'E'	'F'	'G'	O-RING
00.50	7.17 (182.1)	3.48 (88.5)	3.50 (88.9)	11.52 (292.6)	15.21 (386.3)	7.36 (186.9)	15.40 (391.1)	#112
00.75	7.72 (196.1)	4.03 (102.4)	4.00 (101.6)	12.07 (306.6)	15.76 (400.3)	7.91 (200.9)	15.95 (405.1)	
01.00	8.27 (210.0)	4.58 (116.3)	4.50 (114.3)	12.62 (320.5)	16.31 (414.3)	8.46 (214.9)	16.50 (419.1)	
01.25 & 01.50	9.53 (242.1)	5.84 (148.3)	5.50 (139.7)	13.87 (352.3)	17.56 (446.0)	9.72 (246.9)	17.75 (450.8)	#114
02.00	9.97 (253.2)	6.28 (159.5)	6.25 (158.8)	14.32 (363.7)	18.01 (457.4)	10.16 (258.1)	18.20 (462.3)	

DIMENSIONS SHOWN IN ( ) PARENTHESES ARE MILLIMETERS.

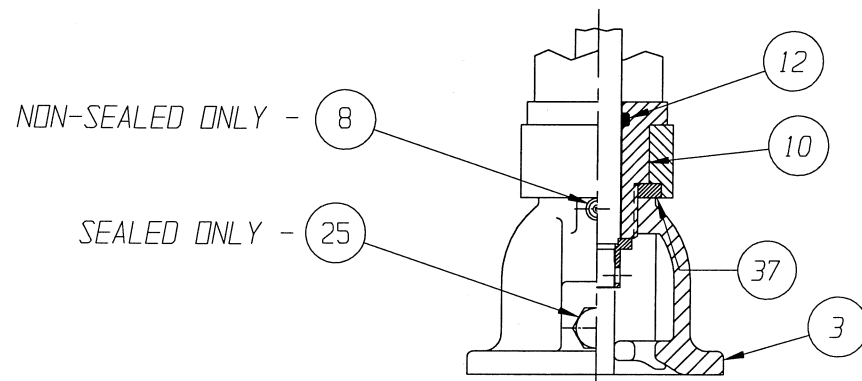
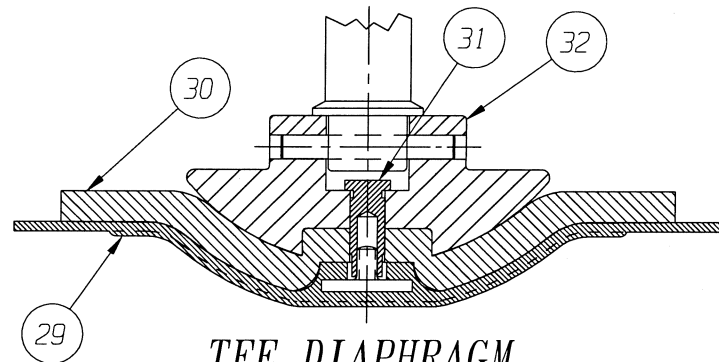

00.50 THRU 01.00  
STEEL BONNET  
YOKE MOUNTED

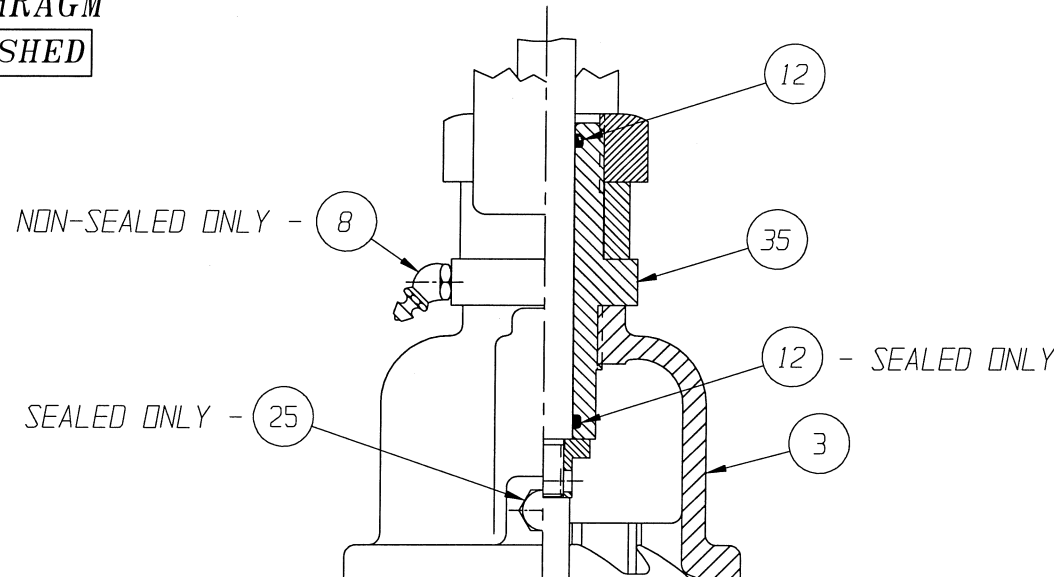

01.25 - 02.00  
STEEL BONNET  
YOKE MOUNTED

LIST OF PARTS			
ITEM	DESCRIPTION	MATERIAL	QTY.
1	BODY, BUTTWELD PIPE	-	1
* 2	DIAPHRAGM, ELASTOMER	-	1
3	BONNET, ADAPTER	-	1
4	HEX, CAP SCREWS OR STUDS	-	4
5	NUTS	-	4
6	COMPRESSOR, F/ ELASTOMER DIAPHRAGM	ZINC B-86	1
7	PIN, SPIROL	STN. STL. TYPE 302	1
8	FITTING, LUBE	-	1
9	SPINDLE, VALVE	STN. STL. A-582, TYPE 303	1
10	BUSHING, ADAPTER	-	1
11	NUT, HEAVY HEX. JAM	CAR. STL.	1
* 12	O-RING 'SEE CHART'	BUNA-N	AR
13	COVER, LOWER	ALUMINUM	1
* 14	DIAPHRAGM, AIR MOTOR	BUNA-N	1
15	COVER, UPPER	ALUMINUM	1
16	PLATE, ACTUATOR	ALUMINUM B-85, SC84A	2
17	NUT, HEX.	CAR. STL.	1
18	SCREW, HEX HD. CAP	CAR. STL.	12
19	NUT, HEX	CAR. STL.	12
20	SPINDLE, VALVE YOKE	STN. STL. A-582, TYPE 303	1
21	YOKE	D.I. A-395, GR. 60-40-18	1
22	COUPLING, HALF	STN. STL. A-351, GR. CF8	2
23	SCREW, HEX HD. CAP	CAR. STL.	2
24	NUT, HEX	CAR. STL.	2
25	PLUG, VENT	STN. STL. TYPE 304	1
26	SPINDLE, ACTUATOR	STN. STL. A-582, TYPE 302	1
27	PLATE, IDENTIFICATION	STN. STL. A-240, TYPE 304	1
28	SCREW, DRIVE TYPE U	CAR. STL. SAE GR.2	4
* 29	DIAPHRAGM, PTFE	R2	1
* 30	CUSHION, BACKING	ELASTOMER	1
31	NUT, TUBE	BRASS B-16, C36000 H02	1
32	COMPRESSOR, F/ PLASTIC DIAPHRAGM	ZINC B-86	1
33	SPRING #88	STEEL	1
34	SPRING #89	STEEL	1
35	BUSHING, ADAPTER	CAR. STL. A-108, GR.12L14	1
Δ 36	SPACER	CAR. STL.	1
▲ 37	SPACER, YOKE	BRASS	1
38	RING, RETAINING	STEEL	1
39	ROD, INDICATING	STN. STL. 18-8	1
40	SPRING, #99	STEEL	1
41	CAP	PLASTIC	1
42	WASHER, SPRINGLOCK	CAR. STL.	2
43	WASHER	NYLON	1

\* RECOMMENDED SPARE PARTS

NOTE:  
 Δ 1. FOR USE WITH 01.25 THRU 02.00 VALVE ASSEMBLIES,  
 ALSO VALVE TRAVEL WILL BE RESTRICTED TO 0.62.  
 ▲ 2. USED ONLY WITH 00.50" STN. STL. BONNET.

ENGRD VALVES ORDER: - \_\_\_\_\_ ITEM: - \_\_\_\_\_  
 SHEET - \_\_\_\_\_ OF - \_\_\_\_\_  
 FIGURE NO.: - \_\_\_\_\_  
 CUSTOMER: - \_\_\_\_\_  
 CUSTOMER P.O.: - \_\_\_\_\_  
 ISSUED BY: \_\_\_\_\_ CERTIFIED BY: \_\_\_\_\_

THIRD ANGLE PROJECTION		DATE	BY	VALVE ASSEMBLY WEIR 00.50 THRU 02.00 #12 REVERSE ACTUATOR WITH BUTTWELD ENDS (PIPE)	<b>ITT Industries</b> Engineered Valves Lancaster, PA USA	
		DWN	01-25-02			BLM
		CHKD	01-25-02			STD
ECN# 6601	UNLESS OTHERWISE SPECIFIED, ALL DIMENSIONS ARE IN INCHES	APVD	01-25-02	STD	CS D 004188 SHEET 2 OF 2	