

ENGRD VALVES ORDER: - ITEM: -
 SHEET - OF -
 FIGURE NO.: -
 CUSTOMER: -
 CUSTOMER P.O.: -
 ISSUED BY: _____ CERTIFIED BY: _____

UNLESS OTHERWISE SPECIFIED, DIMENSIONS NOT SHOWN IN BRACKETS [] ARE IN INCHES.
 DIMENSIONS SHOWN IN BRACKETS [] ARE IN MILLIMETERS.

THIRD ANGLE PROJECTION	DATE	BY
	DWN	11-15-06 JLW
	CHKD	11-15-06 STD
	APVD	11-15-06 STD

VALVE ASSEMBLY
 WEIR 00.75 - 02.00
 #12 REVERSE ACTING
 W/ FLANGED ENDS
 PLASTIC LINED

		Engineered Valves Group Lancaster, PA USA
CS	D	004194
		SHEET 1 OF 2
		REV 0

ECN# 10671

ALL DIMENSIONS SHOWN ON THIS DRAWING ARE FOR REFERENCE ONLY

VALVE SIZE	'A'	'B'	'C'	'D' DIA	'E' DIA	'F' DIA	'G'	'H'	'J'	'K'	'L'	'M'	O-RING (ITEM #12)
00.75	8.38	4.65	5.75	3.88 [98.6]	.500 -13 UNC	2.75 [69.9]	1.69 [42.9]	8.54	16.41	12.68	16.57	0.19	#112
01.00	[212.9]	[118.1]	[146.1]	4.25 [108.0]	0.62 [15.7]	3.12 [79.2]	2.00 [50.8]	[216.9]	[416.8]	[322.1]	[420.9]	[4.8]	
01.25	9.72	5.99	6.88	5.00	.500 -13 UNC	3.50 [88.9]	2.50 [63.5]	9.88	18.25	14.52	18.41	0.20	#114
01.50	[246.9]	[152.1]	[174.8]	[127.0]	0.62 [15.7]	3.88 [98.6]	2.88 [73.2]	[251.0]	[463.6]	[368.8]	[467.6]	[5.1]	
02.00	10.08 [256.0]	6.36 [161.5]	7.88 [200.2]	6.00 [152.4]	0.75 [19.1]	4.75 [120.7]	3.62 [91.9]	10.24 [260.1]	18.61 [472.7]	14.89 [378.2]	18.77 [476.8]	0.22 [5.6]	

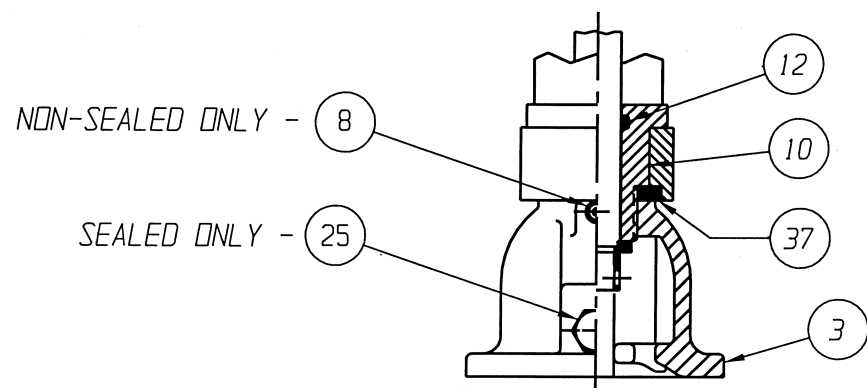
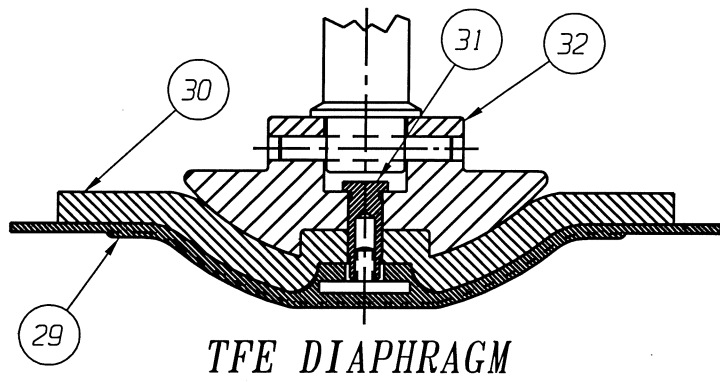

00.75 & 01.00
STEEL BONNET
YOKE MOUNTED

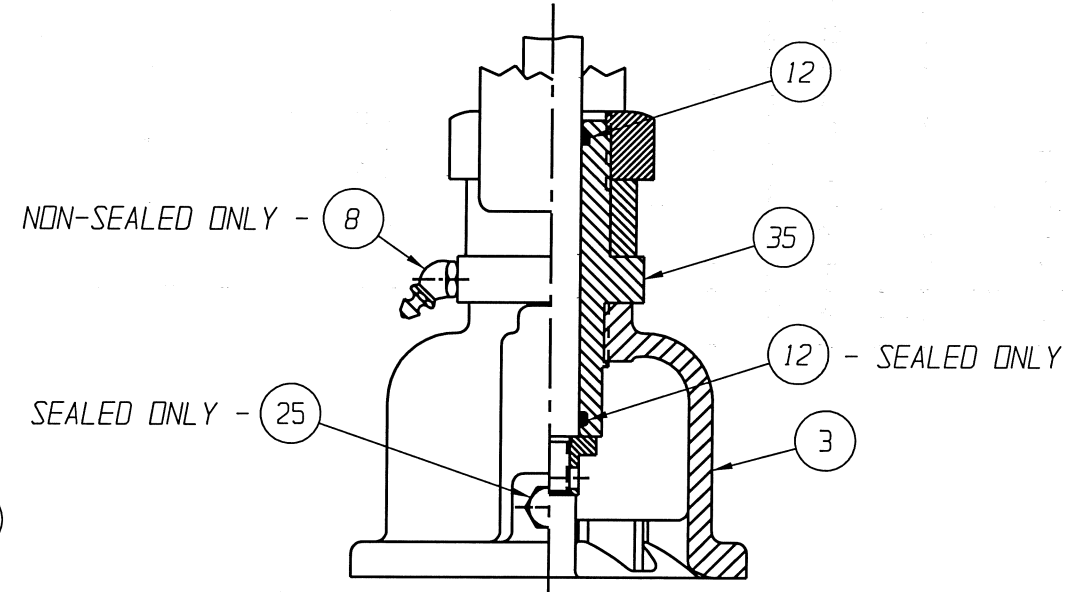

01.25 - 02.00
STEEL BONNET
YOKE MOUNTED

LIST OF PARTS			
ITEM	DESCRIPTION	MATERIAL	QTY.
1	BODY, FLANGED PLASTIC LINED	-	1
* 2	DIAPHRAGM, ELASTOMER	-	1
3	BONNET, ADAPTER	-	1
4	HEX. CAP SCREWS OR STUDS	-	4
5	NUTS	-	4
6	COMPRESSOR, F/ ELASTOMER DIAPHRAGM	ZINC B-86	1
7	PIN, SPIROL	STN. STL. TYPE 302	1
8	FITTING, LUBE	-	1
9	SPINDLE, VALVE	STN. STL. A-582, TYPE 303	1
10	BUSHING, ADAPTER	BRASS	1
11	NUT, HEAVY HEX. JAM	C. STL.	1
* 12	O-RING 'SEE CHART'	BUNA-N	AR
13	COVER, LOWER	ALUMINUM	1
* 14	DIAPHRAGM, AIR MOTOR	BUNA-N	1
15	COVER, UPPER	ALUMINUM	1
16	PLATE, ACTUATOR	ALUMINUM B85, SC84A	2
17	NUT, HEX	CAR. STL.	1
18	SCREW, HEX HD. CAP	CAR. STL.	12
19	NUT, HEX	CAR. STL.	12
20	SPINDLE, VALVE YOKE	STN. STL. A-582, TYPE 303	1
21	YOKE	D.I. A-395, GR. 60-40-18	1
22	COUPLING, HALF	STN. STL. A-351, GR. CF8	2
23	SCREW, HEX HD. CAP	CAR. STL.	2
24	NUT, HEX	CAR. STL.	2
25	PLUG, VENT	STN. STL. TYPE 304	1
26	SPINDLE, ACTUATOR	STN. STL. A-582, TYPE 302	1
27	PLATE, IDENTIFICATION	STN. STL. A-240, TYPE 304	1
28	SCREW, DRIVE TYPE U	CAR. STL. SAE GR.2	4
* 29	DIAPHRAGM, PTFE	R2	1
* 30	CUSHION, BACKING	ELASTOMER	1
31	NUT, TUBE	BRASS B-16, C36000 H02	1
32	COMPRESSOR, F/ PLASTIC DIAPHRAGM	ZINC B-86	1
33	SPRING #88	STEEL	1
34	SPRING #89	STEEL	1
35	BUSHING, ADAPTER	CAR. STL. A-108, GR.12L14	1
Δ 36	SPACER	CAR. STL.	1
Δ 37	SPACER, YOKE	BRASS	1
38	RING, RETAINING	STEEL	1
39	ROD, INDICATING	STN. STL. 18-8	1
40	SPRING, #99	STEEL	1
41	CAP	PLASTIC	1
42	WASHER, SPRINGLOCK	CAR. STL.	2
43	WASHER	NYLON	1

* RECOMMENDED SPARE PARTS

NOTE:
 Δ 1. FOR USE WITH 01.25 THRU 02.00 VALVE ASSEMBLIES, ALSO VALVE TRAVEL WILL BE RESTRICTED TO 0.62.
 Δ 2. USED ONLY WITH 00.50" STN. STL. BONNET.
 3. VALVE IS BI-DIRECTIONAL (NO FLOW ARROW).

ENGRD VALVES ORDER: _____ ITEM: _____
 SHEET _____ OF _____
 FIGURE NO.: _____
 CUSTOMER: _____
 CUSTOMER P.O.: _____
 ISSUED BY: _____ CERTIFIED BY: _____

UNLESS OTHERWISE SPECIFIED, DIMENSIONS NOT SHOWN IN BRACKETS [] ARE IN INCHES.
 DIMENSIONS SHOWN IN BRACKETS [] ARE IN MILLIMETERS.

THIRD ANGLE PROJECTION		DATE	BY
	DWN	11-15-06	JLW
	CHKD	11-15-06	STO
	APVD	11-15-06	STO

VALVE ASSEMBLY
 WEIR 00.75 - 02.00
 #12 REVERSE ACTING
 W/ FLANGED ENDS
 PLASTIC LINED

ITT Engineered Valves Group
 Lancaster, PA USA

CS D 004194 REV D
 SHEET 2 OF 2
 www.engvalves.com

ECN# 10671

ALL DIMENSIONS SHOWN ON THIS DRAWING ARE FOR REFERENCE ONLY